

# DL5B

## SOLENOID OPERATED DIRECTIONAL VALVE COMPACT VERSION

SERIES 10

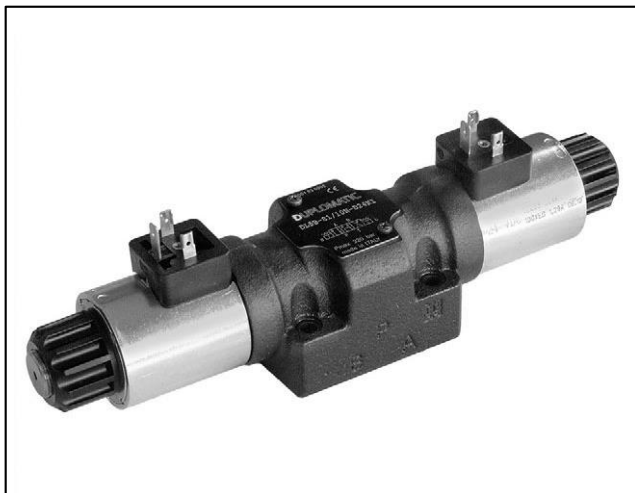

### SUBPLATE MOUNTING ISO 4401-05

p max 320 bar  
Q max 125 l/min

### MOUNTING SURFACE

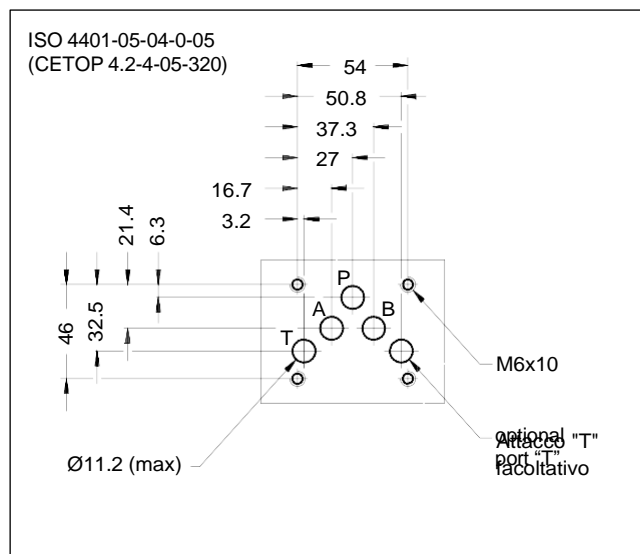

### PERFORMANCES

(with mineral oil of viscosity of 36 cSt at 50°C)

Maximum operating pressure: - ports P - A - B - port T	bar	320 210
Maximum flow rate	l/min	
Pressure drop $\Delta p-Q$	see paragraph 4	
Operating limits	see paragraph 6	
Electrical features	see paragraph 7	
Electrical connections	see paragraph 9	
Ambient temperature range	°C	-20 / +50
Fluid temperature range	°C	-20 / +80
Fluid viscosity range	cSt	10 ÷ 400
Fluid contamination degree	according to ISO 4406:1999 class 20/18/15	
Recommended viscosity	cSt	25
Masse: single solenoid valve double solenoid valve	kg	2,1 2,7

### OPERATING PRINCIPLE

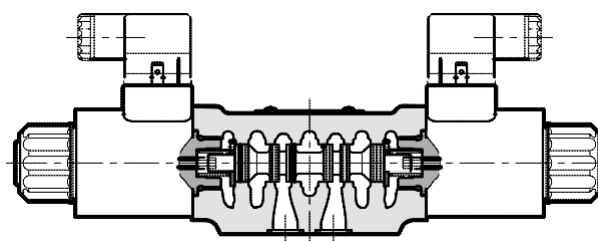

- Direct acting, subplate mounting directional control valve, with mounting surface according to ISO 4401 standards.
- The valve is suitable for special applications, guaranteed by the reduced solenoid dimensions.
- The valve body is made with high strength iron castings provided with wide internal passages in order to minimize the flow pressure drop. Wet armature solenoids with interchangeable coils are used (for further information on solenoids see paragraph 7).
- The valve is supplied with 3 or 4 way designs, and several types of spools.
- The valve is available with DC current solenoids only.
- The valve is also available with zinc-nickel coating that ensures a salt spray resistance up to 600 hours.
- Alternative to the standard manual override there are push, boot, knob and mechanical detent devices.

Архангельск (8182)63-90-72  
Астана (7172)727-132  
Астрахань (8512)99-46-04  
Барнаул (3852)73-04-60  
Белгород (4722)40-23-64  
Брянск (4832)59-03-52  
Владивосток (423)249-28-31  
Волгоград (844)278-03-48  
Вологда (8172)26-41-59  
Воронеж (473)204-51-73  
Екатеринбург (343)384-55-89  
Иваново (4932)77-34-06

Ижевск (3412)26-03-58  
Иркутск (395)279-98-46  
Казань (843)206-01-48  
Калининград (4012)72-03-81  
Калуга (4842)92-23-67  
Кемерово (3842)65-04-62  
Киров (8332)68-02-04  
Краснодар (861)203-40-90  
Красноярск (391)204-63-61  
Курск (4712)77-13-04  
Липецк (4742)52-20-81

Магнитогорск (3519)55-03-13  
Москва (495)268-04-70  
Мурманск (8152)59-64-93  
Набережные Челны (8552)20-53-41  
Нижний Новгород (831)429-08-12  
Новокузнецк (3843)20-46-81  
Новосибирск (383)227-86-73  
Омск (3812)21-46-40  
Орел (4862)44-53-42  
Оренбург (3532)37-68-04  
Пенза (8412)22-31-16

Пермь (342)205-81-47  
Ростов-на-Дону (863)308-18-15  
Рязань (4912)46-61-64  
Самара (846)206-03-16  
Санкт-Петербург (812)309-46-40  
Саратов (845)249-38-78  
Севастополь (8692)22-31-93  
Симферополь (3652)67-13-56  
Смоленск (4812)29-41-54  
Сочи (862)225-72-31  
Ставрополь (8652)20-65-13

Сургут (3462)77-98-35  
Тверь (4822)63-31-35  
Томск (3822)98-41-53  
Тула (4872)74-02-29  
Тюмень (3452)66-21-18  
Ульяновск (8422)24-23-59  
Уфа (347)229-48-12  
Хабаровск (4212)92-98-04  
Челябинск (351)202-03-61  
Череповец (8202)49-02-64  
Ярославль (4852)69-52-93

Киргизия (996)312-96-26-47

Россия (495)268-04-70

Казахстан (772)734-952-31

## 1 - IDENTIFICATION CODE

### 1.1 - Standard version

	<b>D</b>	<b>L</b>	<b>5</b>	<b>B</b>	-	/	<b>10</b>	-		/	
--	----------	----------	----------	----------	---	---	-----------	---	--	---	--

Directional valve, solenoid operated

Compact version

ISO 4401-05 size

Spool type (see paragraph 3):

<b>S*</b>	<b>TA*</b>
<b>SA*</b>	<b>TB*</b>
<b>SB*</b>	<b>RK</b>

Series no. (the overall and mounting dimensions remain unchanged from 10 to 19)

Seals:

**N** = NBR seals for mineral oil (**standard**)

**V** = FPM seals for special fluids

Option:

**/ W7** = Zinc-nickel surface treatment (see **NOTE**)  
Omit if not required

Manual override (see par. 12):  
Omit for override integrated in the tube (**standard**)

**CM** = manual override, boot protected

**CP** = push manual override

**CK1** = turning knob override

**CPK** = push manual override with mechanical retention

Coil electrical connection (see par. 9):

**K1** = plug for connector type EN 175301-803 (ex DIN 43650) (**standard**)

**K2** = plug for connector type AMP JUNIOR (available on **D12** and **D24** coils only)

**K7** = plug DEUTSCH DT04-2P for male connector type DEUTSCH DT06-2S (available on **D12** and **D24** coils only)

DC power supply

**D12** = 12 V

**D24** = 24 V

**D28** = 28 V

**D00** = valve without coils (coils locking ring and related OR are supplied together with the valves.)

**NOTE:** The standard valve is supplied with surface treatment of phosphating black.

The zinc-nickel finishing on the valve body makes the valve suitable to ensure a salt spray resistance up to **240** hours. For a salt spray resistance up to **600** hours refer to **paragraph 13**.

(test operated according to UNI EN ISO 9227 standards and test evaluation operated according to UNI EN ISO 10289 standards).

## 2 - HYDRAULIC FLUIDS

Use mineral oil-based hydraulic fluids HL or HM type, according to ISO 6743-4. For these fluids, use NBR seals (code N). For fluids HFDR type (phosphate esters) use FPM seals (code V). For the use of other fluid types such as HFA, HFB, HFC, please consult our technical department.

Using fluids at temperatures higher than 80 °C causes a faster degradation of the fluid and of the seals characteristics. The fluid must be preserved in its physical and chemical characteristics.

### 3 - SPOOL TYPE

**Type S\*:**  
2 solenoids - 3 positions  
with spring centring

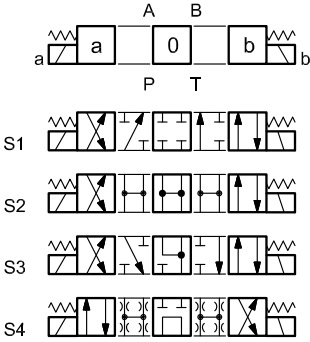

**Type SA\*:**  
1 solenoid side A  
2 positions (central + external)  
with spring centring

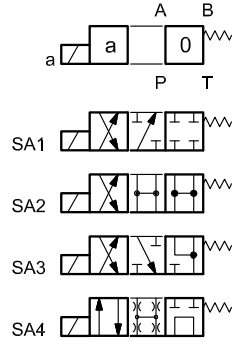

**Type SB\*:**  
1 solenoid side B  
2 positions (central + external)  
with spring centring

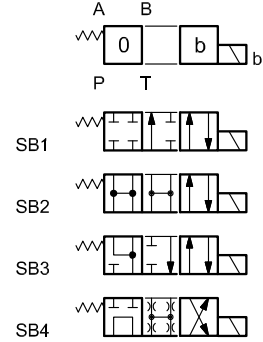

**Type RK:**  
2 solenoids - 2 positions  
with mechanical retention

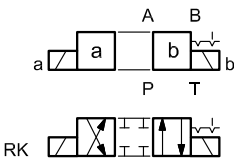

**Type TA:**  
1 solenoid side A  
2 external positions  
with return spring

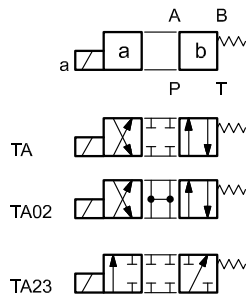

**Type TB:**  
1 solenoid side B  
2 external positions  
with return spring

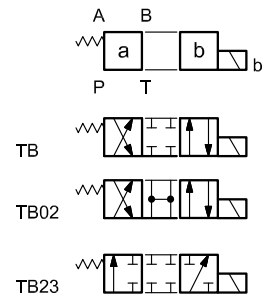

**NOTE:** Further spools available on request only.

### 4 - PRESSURE DROPS $\Delta p$ -Q

(obtained with viscosity of 36 cSt at 50 °C)

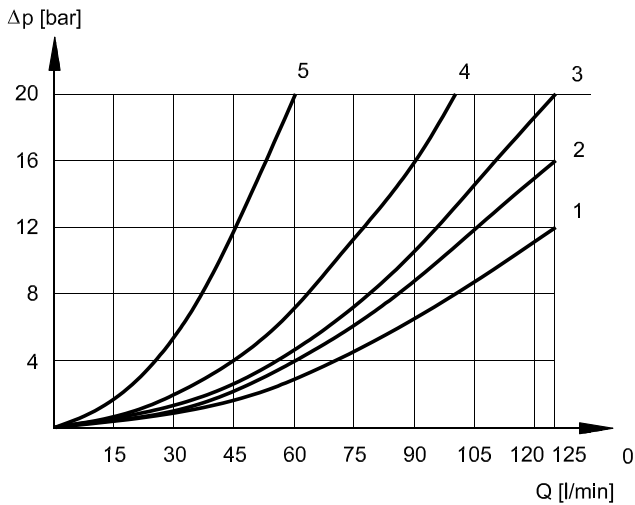

#### ENERGIZED VALVE

SPOOL	FLOW DIRECTIONS			
	P→A	P→B	A→T	B→T
	CURVES ON GRAPHS			
S1	1	1	2	2
S2	1	1	1	1
S3	1	1	1	1
S4	4	4	4	4
RK	2	2	2	2
TA	2	2	3	3
TA02	2	2	1	1
TA23	3	3	-	-

#### DE-ENERGIZED VALVE

SPOOL	FLOW DIRECTIONS		
	A→T	B→T	P→T
	CURVES ON GRAPHS		
S2	-	-	1
S3	5	5	-
S4	-	-	1

### 5 - SWITCHING TIMES

The values indicated are obtained with spool S1, according to ISO 6403 standard, with mineral oil viscosity 36 cSt at 50°C.

SUPPLY	TIMES ( $\pm 10\%$ ) [ms]	
		DE-ENERGIZING
DC	70 ÷ 100	15 ÷ 20

### 6 - OPERATING LIMITS

The curves define the flow rate operating fields according to the valve pressure of the different versions. The values have been obtained according to ISO 6403 norm with solenoids at rated temperature and supplied with voltage equal to 90% of the nominal voltage. The values have been obtained with mineral oil, viscosity 36 cSt, temperature 50 °C and filtration according to ISO 4406:1999 class 18/16/13.

The limits for TA02 and TA spools refer to the 4-way operation. The operating limits of a 4-way valve in 3-way operation or with port A or B plugged or without flow are shown in the chart on the next page.

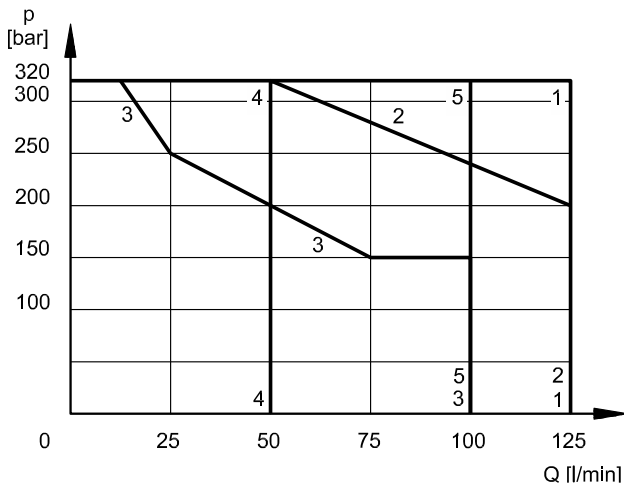

SPOOL	CURVE
S1, S2, RK	1
TA02	2
S3	3
S4	4
TA, TA23	5

### 6.1 - 4-way valve in 3-way operation

Operating limits of a 4-way valve in 3-way operation or with port A or B plugged or without flow.

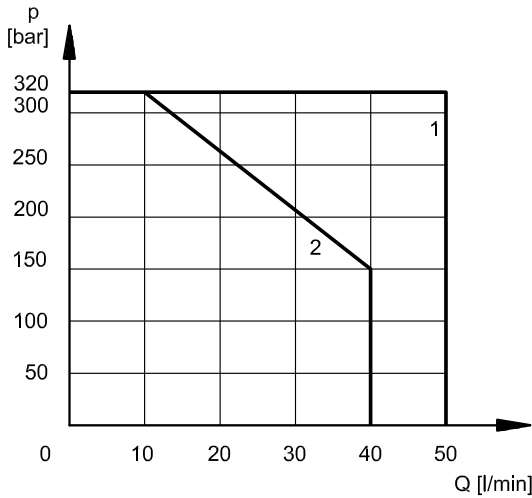

SPOOL	CURVE
TA	1
TA02	2

## 7 - ELECTRICAL FEATURES

### 7.1 - Solenoids

These are essentially made up of two parts: tube and coil. The tube is threaded into the valve body and includes the armature that moves immersed in oil, without wear. The inner part, in contact with the oil in the return line, ensures heat dissipation.

The coil is fastened to the tube by a threaded ring. The coils are interchangeable.

### Protection from atmospheric agents IEC 60529

The IP protection degree is guaranteed only with both valve and connectors of an equivalent IP degree, correctly connected and installed.

electric connection	electric connection protection	whole valve protection
K1 EN 175301-803 (ex DIN 43650)	IP65	IP65
K2 AMP JUNIOR	IP65/67	
K7 DEUTSCH DT04 male	IP65/67	

<b>SUPPLY VOLTAGE FLUCTUATION</b>	± 10% Vnom
<b>MAX SWITCH ON FREQUENCY</b>	10.000 ins/hr
<b>DUTY CYCLE</b>	100%
<b>ELECTROMAGNETIC COMPATIBILITY (EMC)</b>	In compliance with 2014/30/EU
<b>LOW VOLTAGE (NOTE)</b>	In compliance with 2014/35/EU
<b>CLASS OF PROTECTION</b> Coil insulation (VDE 0580) Impregnation	class H class F

**NOTE:** In order to further reduce the emissions, use of type H connectors is recommended, because of they prevent voltage peaks at the opening of the coil supply electrical circuit (see cat. 49 000).

### 7.2 - Coils current and power consumption

The table below shows the consumption values relating to the various types of coils for direct current power supply.

(values ±10%)

	Nominal voltage [V]	Resistance at 20°C [Ω]	Current consumption [A]	Power consumption [W]	Coil code		
					K1	K2	K7
<b>D12</b>	12	4,4	2,72	32,7	1903080	1903100	1902940
<b>D24</b>	24	18,6	1,29	31	1903081	1903101	1902941
<b>D28</b>	28	26	1,11	31	1903082		-

### 8 - INSTALLATION

The configuration with centring and return springs can be mounted in any position.

Valve fitting takes place by means of screws or tie rods, fixing the valve on a lapped surface, with values of planarity and smoothness that are equal to or better than those indicated in the drawing. If the minimum values of planarity or smoothness are not met, fluid leakages between valve and mounting surface can easily occur.

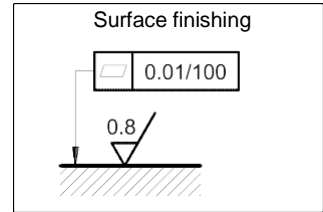

### 9 - ELECTRIC CONNECTIONS

connection for EN 175301-803  
(ex DIN 43650) connector  
code **K1 (standard)**  
code **WK1** (W7 version only)

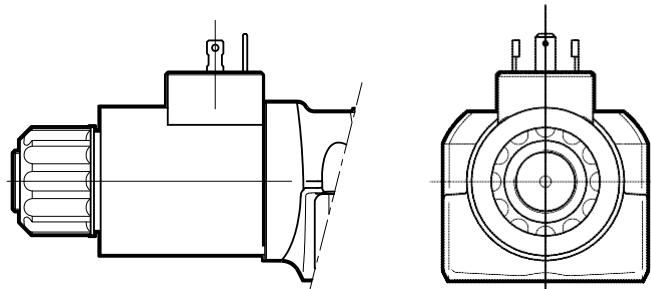

connection for AMP JUNIOR  
connector  
code **K2**

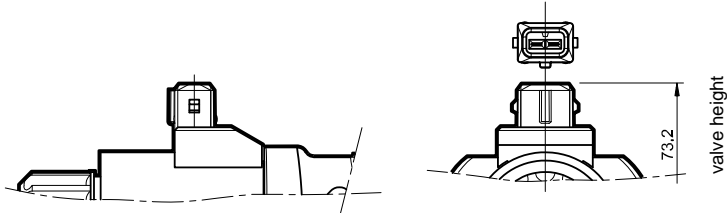

connection for  
DEUTSCH DT06-2S male connector  
code **K7**

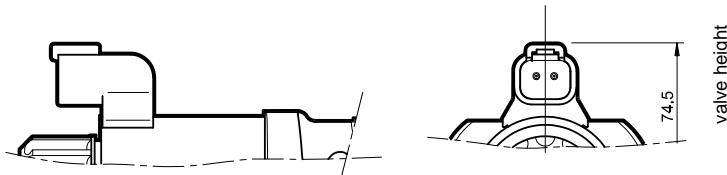

connection for  
DEUTSCH DT06-2S male  
connector  
code **WK7** (W7 version only)

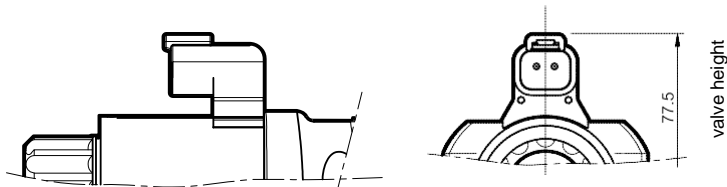

connection for  
DEUTSCH DT06-2S male  
connector - coil with diode  
code **WK7D** (W7 version only)

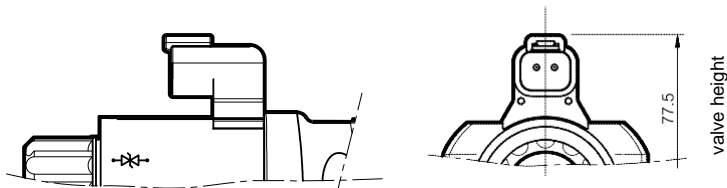

## 10 - ELECTRIC CONNECTORS

Solenoid operated valves are delivered without connectors. Connectors type EN 175301-803 (ex DIN 43650) for K1 and WK1 connections can be ordered separately. See catalogue 49 000.

## 11 - OVERALL AND MOUNTING DIMENSIONS

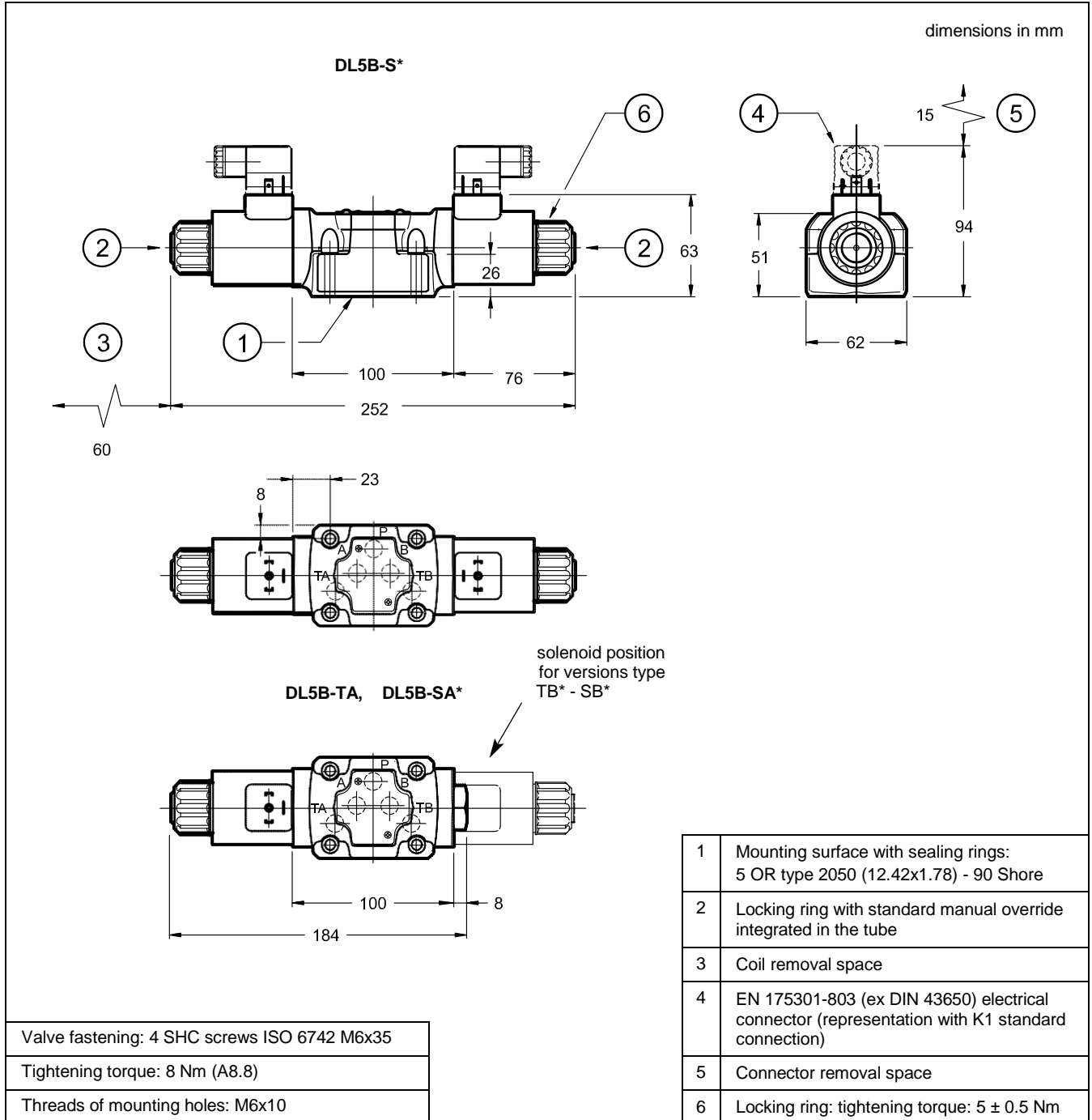

## 12 - MANUAL OVERRIDES

12.1 - CM Manual override, boot protected

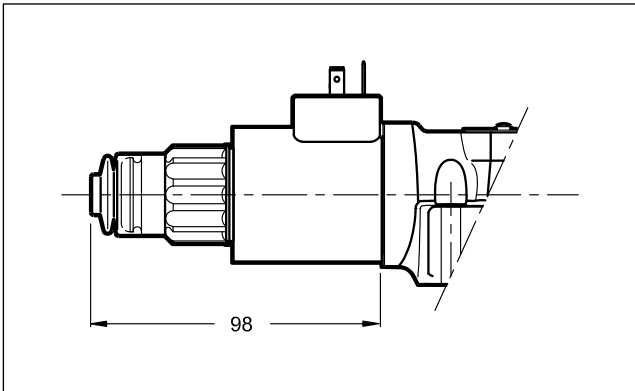

12.2 - CP Push manual override

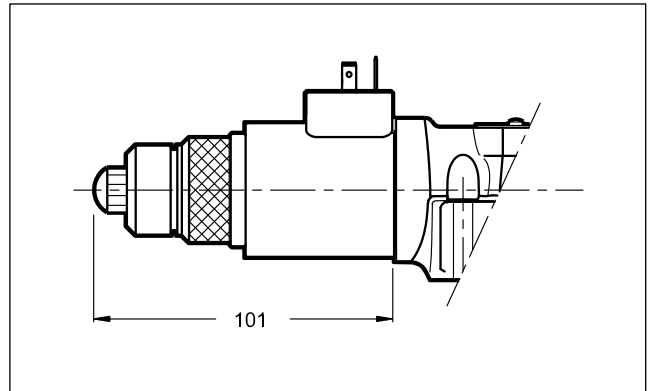

12.3 - CPK Push manual override with mechanical retention

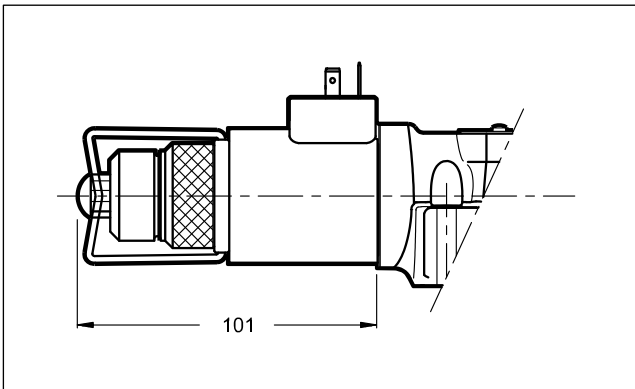

12.4 - CK1 Turning knob override

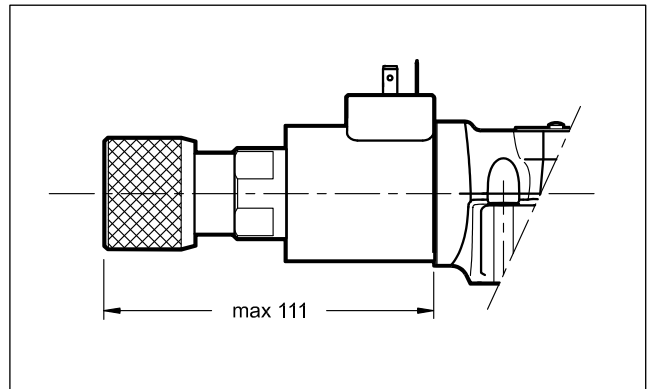



## 13 - HIGH IP AND CORROSION RESISTANCE VERSION

### 13.1 - Identification code

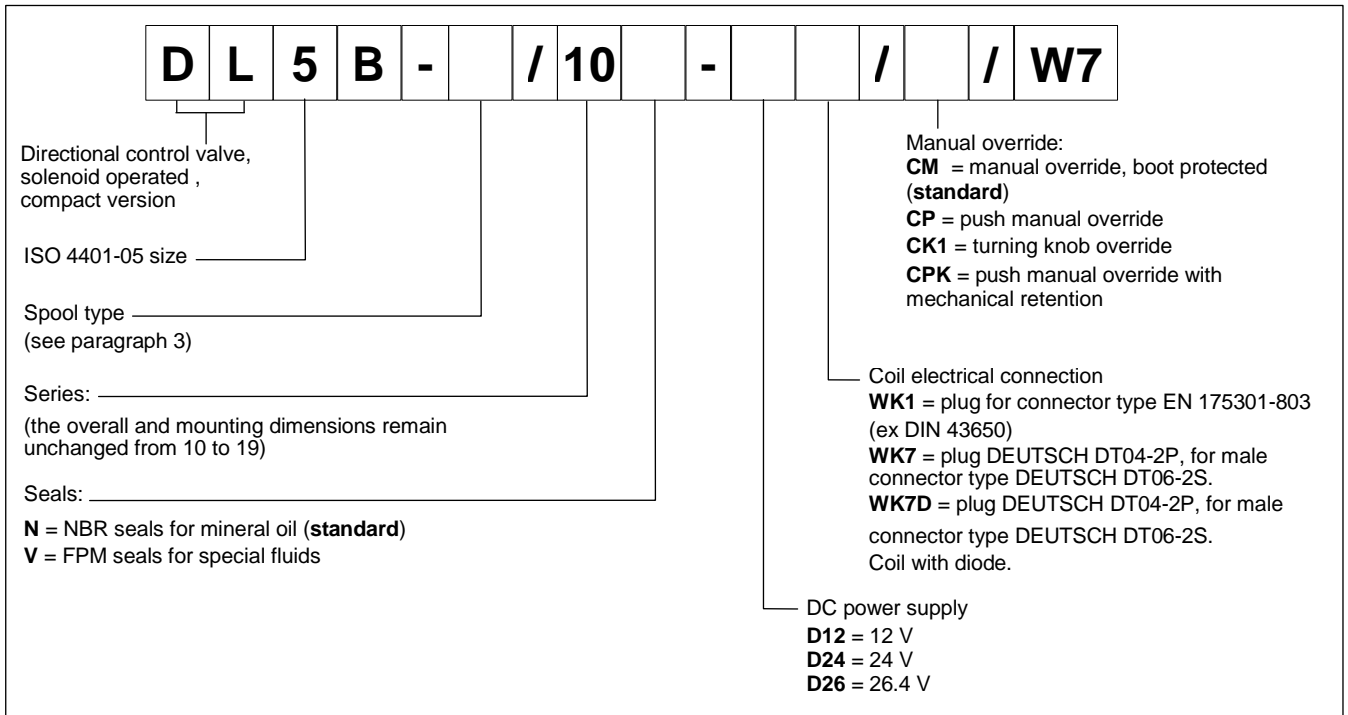

### 13.2 - Corrosion resistance

This version features the zinc-nickel coating on all exposed metal parts of the valve, making it resistant to exposure to the salt spray for **600** hours (test performed according to UNI EN ISO 9227 and assessment test performed according to UNI EN ISO 10289).

### 13.3 - DC coils

The coils feature a zinc-nickel surface treatment.

The WK7D coil includes a suppressor diode of pulses for protection from voltage peaks during switching. During the switching the diode significantly reduces the energy released by the winding, by limiting the voltage to 31.4V in the D12 coil and to 58.9 V in the D24 coil.

(values  $\pm 10\%$ )

	Nominal voltage [V]	Resistance at 20°C [ $\Omega$ ]	Current consumpt. [A]	Power consumpt [W]	Coil code		
					WK1	WK7	WK7D
<b>D12</b>	12	4,4	2,72	32,7	1903590	1903580	1903600
<b>D24</b>	24	18,6	1,29	31	1903591	1903581	1903601
<b>D26</b>	26,4	21,8	1,21	32	1903599	1903589	-

### 13.4 - Protection from atmospheric agents IEC 60529

The IP protection degree is guaranteed only with both valve and connectors of an equivalent IP degree, correctly connected and installed.

electric connection	electric connection protection	whole valve protection
WK1 EN 175301-803 (ex DIN 43650)	IP66	IP66
WK7 DEUTSCH DT04 male	IP66/IP68/IP69 IP69K*	IP66/IP68/IP69 IP69K*
WK7D DEUTSCH DT04 male	IP66/IP68/IP69 IP69K*	IP66/IP68/IP69 IP69K*

(\* The IP69K protection degree is not taken into account in IEC 60529 but it is included in ISO 20653.

**NOTE:** As regards the liquid ingress protection (second digit), there are three means of protection.

Codes from 1 to 6 are related to water jets.

Rates 7 and 8 are related to immersion.

Rate 9 is reserved for high pressure and temperature water jets.

This means that IPX6 covers all the lower steps, rate IPX8 covers IPX7 but not IPX6 and lower, instead IPX9 does not cover any of them.

Whether a device meets two types of protection requirements it must be indicated by listing both the tests separated by a slash.

(E.g. a marking of an equipment covered both by temporary immersion and water jets is IP66/IP68).

## 14 - SPARE PARTS

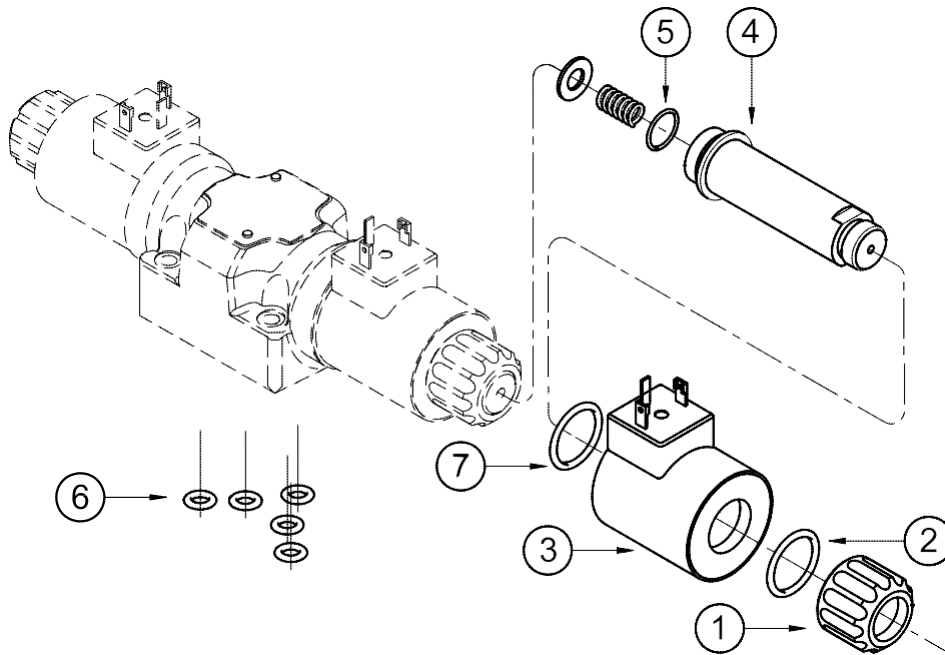

### IDENTIFICATION CODE FOR DC COILS

**C 22 S3 - /**

Supply voltage

**D12** = 12 V  
**D24** = 24 V  
**D26** = 26.4 V  
**D28** = 28 V

Series no.:

**10** = for K7 and WK7  
**11** = for K1, K2 and WK7D  
**12** = for WK1

Coil electrical connection (see par. 9):  
**K1** = plug for connector EN 175301-803 (ex DIN 43650)

for coils **D12**, **D24** and **D26**:

**WK1** = plug for connector EN 175301-803 (ex DIN 43650)

**WK7** = plug DEUTSCH DT04-2P, for male connector type DEUTSCH DT06-2S.

Only for **D12** and **D24**:

**K2** = plug for connector AMP JUNIOR

**K7** = plug DEUTSCH DT04-2P, for male connector type DEUTSCH DT06-2S.

**WK7D** = plug DEUTSCH DT04-2P, for male connector type DEUTSCH DT06-2S.

Coil with diode.

1	Coil locking ring - code 0119412 tightening torque: 5 ±0.5 Nm
2	ORM-0220-20 - 70 shore
3	Coil (see identification code)
4	Solenoid tube: TD22-DL5/10N (NBR seals) TD22-DL5/10V (FPM seals) (OR n° 5 included)
5	OR type 3.910 (19.18x2.46) - 70 shore
6	N. 5 OR type 2050 (12.42x1.78) - 90 Shore
7	Only for coil series 12: ORM-0220-20 - MVQ

### SEAL KIT

The codes included the OR n° 2, 5, 6 and 7.

**Cod. 1985461** NBR seals

**Cod. 1985462** FPM seals

**NOTE:** You can also order coils using the coil codes in paragraphs 7.2 and 13.3.

Архангельск (8182)63-90-72  
 Астана (7172)727-132  
 Астрахань (8512)99-46-04  
 Барнаул (3852)73-04-60  
 Белгород (4722)40-23-64  
 Брянск (4832)59-03-52  
 Владивосток (423)249-28-31  
 Волгоград (844)278-03-48  
 Вологда (8172)26-41-59  
 Воронеж (473)204-51-73  
 Екатеринбург (343)384-55-89  
 Иваново (4932)77-34-06

Ижевск (3412)26-03-58  
 Иркутск (395)279-98-46  
 Казань (843)206-01-48  
 Калининград (4012)72-03-81  
 Калуга (4842)92-23-67  
 Кемерово (3842)65-04-62  
 Киров (8332)68-02-04  
 Краснодар (861)203-40-90  
 Красноярск (391)204-63-61  
 Курск (4712)77-13-04  
 Липецк (4742)52-20-81

Магнитогорск (3519)55-03-13  
 Москва (495)268-04-70  
 Мурманск (8152)59-64-93  
 Набережные Челны (8552)20-53-41  
 Нижний Новгород (831)429-08-12  
 Новокузнецк (3843)20-46-81  
 Новосибирск (383)227-86-73  
 Омск (3812)21-46-40  
 Орел (4862)44-53-42  
 Оренбург (3532)37-68-04  
 Пенза (8412)22-31-16

Пермь (342)205-81-47  
 Ростов-на-Дону (863)308-18-15  
 Рязань (4912)46-61-64  
 Самара (846)206-03-16  
 Санкт-Петербург (812)309-46-40  
 Саратов (845)249-38-78  
 Севастополь (8692)22-31-93  
 Симферополь (3652)67-13-56  
 Смоленск (4812)29-41-54  
 Сочи (862)225-72-31  
 Ставрополь (8652)20-65-13

Сургут (3462)77-98-35  
 Тверь (4822)63-31-35  
 Томск (3822)98-41-53  
 Тула (4872)74-02-29  
 Тюмень (3452)66-21-18  
 Ульяновск (8422)24-23-59  
 Уфа (347)229-48-12  
 Хабаровск (4212)92-98-04  
 Челябинск (351)202-03-61  
 Череповец (8202)49-02-64  
 Ярославль (4852)69-52-93

Киргизия (996)312-96-26-47

Россия (495)268-04-70

Казахстан (772)734-952-31

<https://diplomatic.nt-rt.ru/> || [dcw@nt-rt.ru](mailto:dcw@nt-rt.ru)