

FV6

FIXED DISPLACEMENT VANE PUMPS SERIES 10

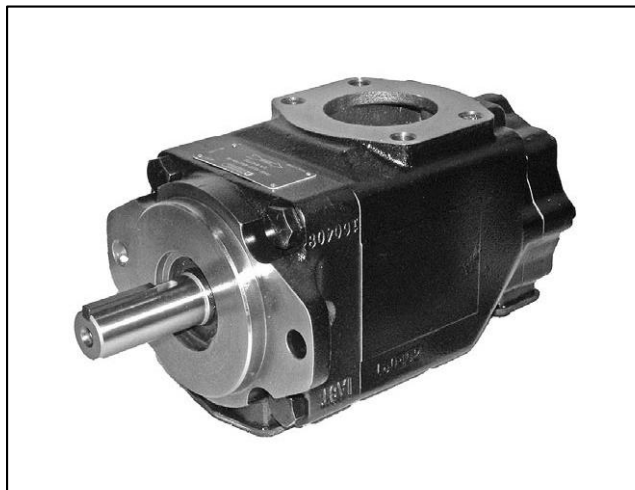

OPERATING PRINCIPLE

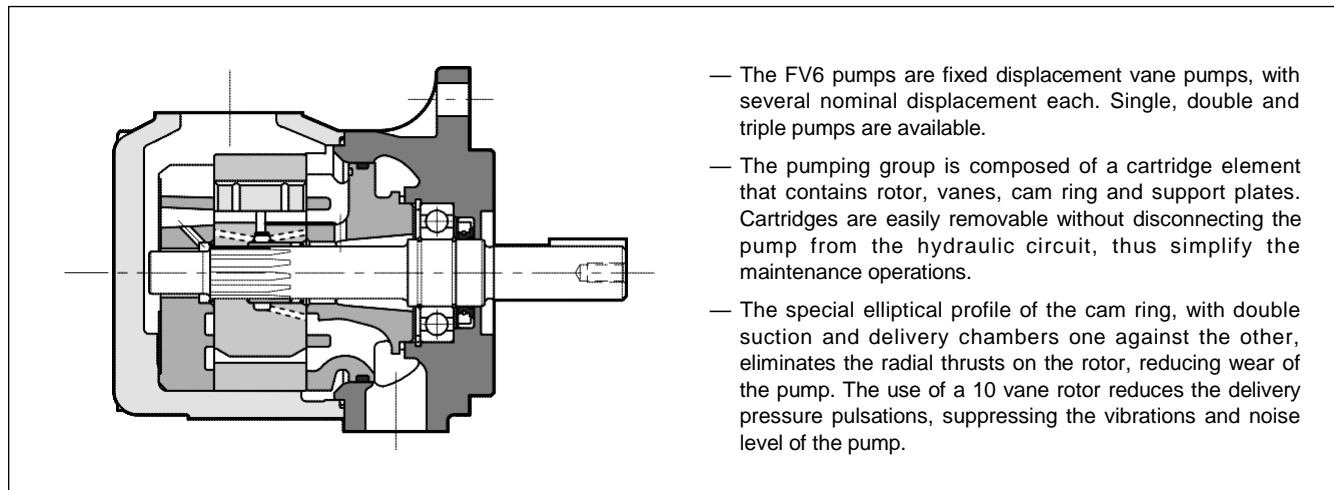

- The FV6 pumps are fixed displacement vane pumps, with several nominal displacement each. Single, double and triple pumps are available.
- The pumping group is composed of a cartridge element that contains rotor, vanes, cam ring and support plates. Cartridges are easily removable without disconnecting the pump from the hydraulic circuit, thus simplify the maintenance operations.
- The special elliptical profile of the cam ring, with double suction and delivery chambers one against the other, eliminates the radial thrusts on the rotor, reducing wear of the pump. The use of a 10 vane rotor reduces the delivery pressure pulsations, suppressing the vibrations and noise level of the pump.

TECHNICAL SPECIFICATIONS

PUMP SIZE (SINGLE)		FV6C	FV6D	FV6E
Displacement range	cm ³ /rev	10.8 ÷ 100	47.6 ÷ 158	132.3 ÷ 269
Flow rate range (at 1500 rpm - 0 bar)	l/min	16.2 ÷ 150	71.4 ÷ 237	198 ÷ 403
Operating pressure	bar	240	210	210
Rotation speed (max)	rpm	2800	2500	2200
Rotation direction		clockwise or anticlockwise		
Loads on shaft		see diagrams		
Hydraulic connections		SAE J518c		
Mounting flange SAE J744		SAE B	SAE C	SAE C
Mass (empty single pump)	kg	15.4	24	43

Ambient temperature range	°C	-20 / +60
Fluid temperature range (see par. 4)	°C	-10 / +70
Fluid viscosity range	cSt	see paragraph 4
Fluid contamination degree	see paragraph 4.3	
Recommended viscosity	cSt	30

HYDRAULIC SYMBOLS

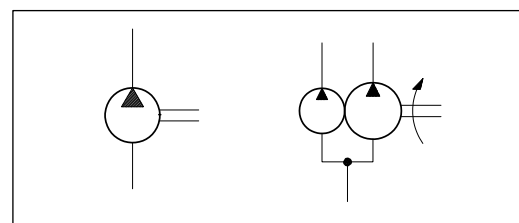

Архангельск (8182)63-90-72
Астана (7172)727-132
Астрахань (8512)99-46-04
Барнаул (3852)73-04-60
Белгород (4722)40-23-64
Брянск (4832)59-03-52
Владивосток (423)249-28-31
Волгоград (844)278-03-48
Вологда (8172)26-41-59
Воронеж (473)204-51-73
Екатеринбург (343)384-55-89
Иваново (4932)77-34-06

Ижевск (3412)26-03-58
Иркутск (395)279-98-46
Казань (843)206-01-48
Калининград (4012)72-03-81
Калуга (4842)92-23-67
Кемерово (3842)65-04-62
Киров (8332)68-02-04
Краснодар (861)203-40-90
Красноярск (391)204-63-61
Курск (4712)77-13-04
Липецк (4742)52-20-81

Магнитогорск (3519)55-03-13
Москва (495)268-04-70
Мурманск (8152)59-64-93
Набережные Челны (8552)20-53-41
Нижний Новгород (831)429-08-12
Новокузнецк (3843)20-46-81
Новосибирск (383)227-86-73
Омск (3812)21-46-40
Краснодар (861)203-40-90
Орел (4862)44-53-42
Оренбург (3532)37-68-04
Пенза (8412)22-31-16

Пермь (342)205-81-47
Ростов-на-Дону (863)308-18-15
Рязань (4912)46-61-64
Самара (846)206-03-16
Санкт-Петербург (812)309-46-40
Саратов (845)249-38-78
Севастополь (8692)22-31-93
Симферополь (3652)67-13-56
Смоленск (4812)29-41-54
Сочи (862)225-72-31
Ставрополь (8652)20-65-13

Сургут (3462)77-98-35
Тверь (4822)63-31-35
Томск (3822)98-41-53
Тула (4872)74-02-29
Тюмень (3452)66-21-18
Ульяновск (8422)24-23-59
Уфа (347)229-48-12
Хабаровск (4212)92-98-04
Челябинск (351)202-03-61
Череповец (8202)49-02-64
Ярославль (4852)69-52-93

Киргизия (996)312-96-26-47

Россия (495)268-04-70

Казахстан (772)734-952-31

1 - IDENTIFICATION CODE FOR SINGLE PUMPS

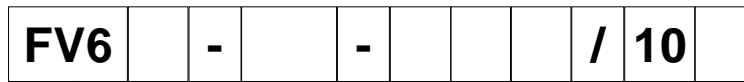

Fixed displacement vane pump with SAE flange

Pump size:
C = from 10.8 to 100 cm³/rev
D = from 47.6 to 158 cm³/rev
E = from 132.3 to 269 cm³/rev

Cartridge size
 see paragraph 2

Shaft end type:

FV6C

- 1 = cylindrical keyed SAE B J744
- 2 = cylindrical keyed no SAE
- 3 = splined SAE B J498b class 1
- 4 = splined SAE B-B J498b class 1

FV6D

- 1 = cylindrical keyed SAE C J744
- 2 = cylindrical keyed no SAE
- 3 = splined SAE C J498b class 1
- 4 = splined no SAE

FV6E

- 1 = cylindrical keyed SAE C-C J744
- 2 = cylindrical keyed no SAE
- 3 = splined SAE C J498b class 1
- 4 = splined SAE C-C J498b class 1

Seals:

- N** = NBR seals for mineral oils (**standard**)
- V** = FPM seals for special fluids

Series No.

(the overall and mounting dimensions remain unchanged from 10 to 19)

Ports position

(view from shaft side)

Pressure port always on top

00 = opposed (**standard**)

01 = in line

02 = 90° CW from P port

03 = 90° CCW 90° CW from P port

Rotation direction

(view from shaft side)

R = clockwise

L = counterclockwise

ports position

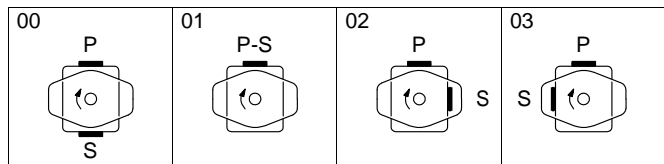



2 - PERFORMANCES

(obtained with antiwear mineral oil with viscosity of 24 cSt)

PUMP	CARTRIDGE SIZE	DISPLACEMENT [cm ³ /rev]	MAX FLOW RATE at 0 bar - 1500 rpm [l/min]	PRESSURE [bar]		ROTATION SPEED [rpm]	
				continuous	peak	max	min
FV6C	03	10.8	16.2	240	280	2800	600
	05	17.2	25.8				
	06	21.3	31.9				
	08	26.4	39.6				
	10	34.1	51.1				
	12	37.1	55.6				
	14	46.0	69.0				
	17	58.3	87.4				
	20	63.8	95.7				
	22	70.3	105.4				
	25	79.3	118.9				
	28	88.8	133.2	160	210	2500	600
	31	100.0	150				
FV6D	14	47.6	71.4	210	250	2500	600
	17	58.2	87.3				
	20	66.0	99.0				
	24	79.5	119.3				
	28	89.7	134.6				
	31	98.3	147.5				
	35	111.0	166.5				
	38	120.3	180.5				
	42	136.0	204.0				
	45	145.7	218.6			160	
50	158.0	237					
FV6E	42	132.3	198.5	210	250	2200	600
	45	142.4	213.6				
	50	158.5	237.8				
	52	164.8	247.2				
	57	179.8	269.6				
	62	196.7	295.1				
	66	213.3	320.0				
	72	227.1	340.0				
	85	269	403	80	120	2000	600



3 - IDENTIFICATION CODE FOR FV6 DOUBLE PUMPS

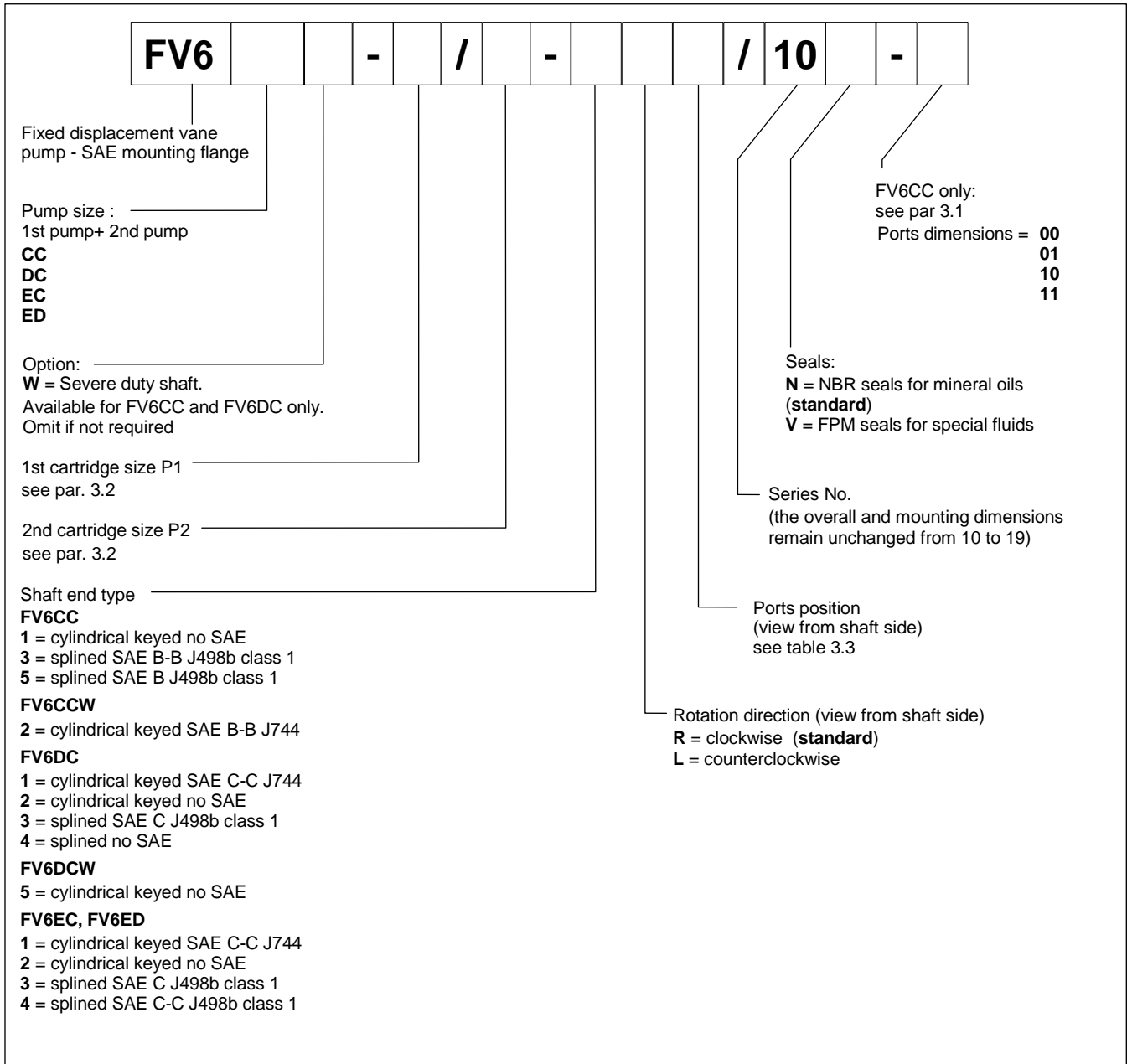

3.1 - Ports dimensions for FV6CC

The largest cartridge must always be installed on the front side.

P2 = 3/4" for 46 ml/rev max
 S = 2" 1/2 for 126 ml/rev max

	P1	P2	S
00	1"	1"	3"
01	1"	3/4"	3"
10	1"	1"	2" 1/2
11	1"	3/4"	2" 1/2

3.2 - Available cartridges

Grey boxes indicates reduced performance. See paragraph 2 for limits.

The second cartridge (for P2) should have equal or lower displacement than the first.

CC		DC		EC		ED	
1st cartridge	2nd cartridge	1st cartridge	2nd cartridge	1st cartridge	2nd cartridge	1st cartridge	2nd cartridge
03	03	14	03	42	03	42	14
05	05	17	05	45	05	45	17
06	06	20	06	50	06	50	20
08	08	24	08	52	08	52	24
10	10	28	10	57	10	57	28
12	12	31	12	62	12	62	31
14	14	35	14	66	14	66	35
17	17	38	17	72	17	72	38
20	20	42	20	85	20	85	42
22	22	45	22		22		45
25	25	50	25		25		50
28	28		28		28		
31	31		31		31		

3.3 - Ports position codes

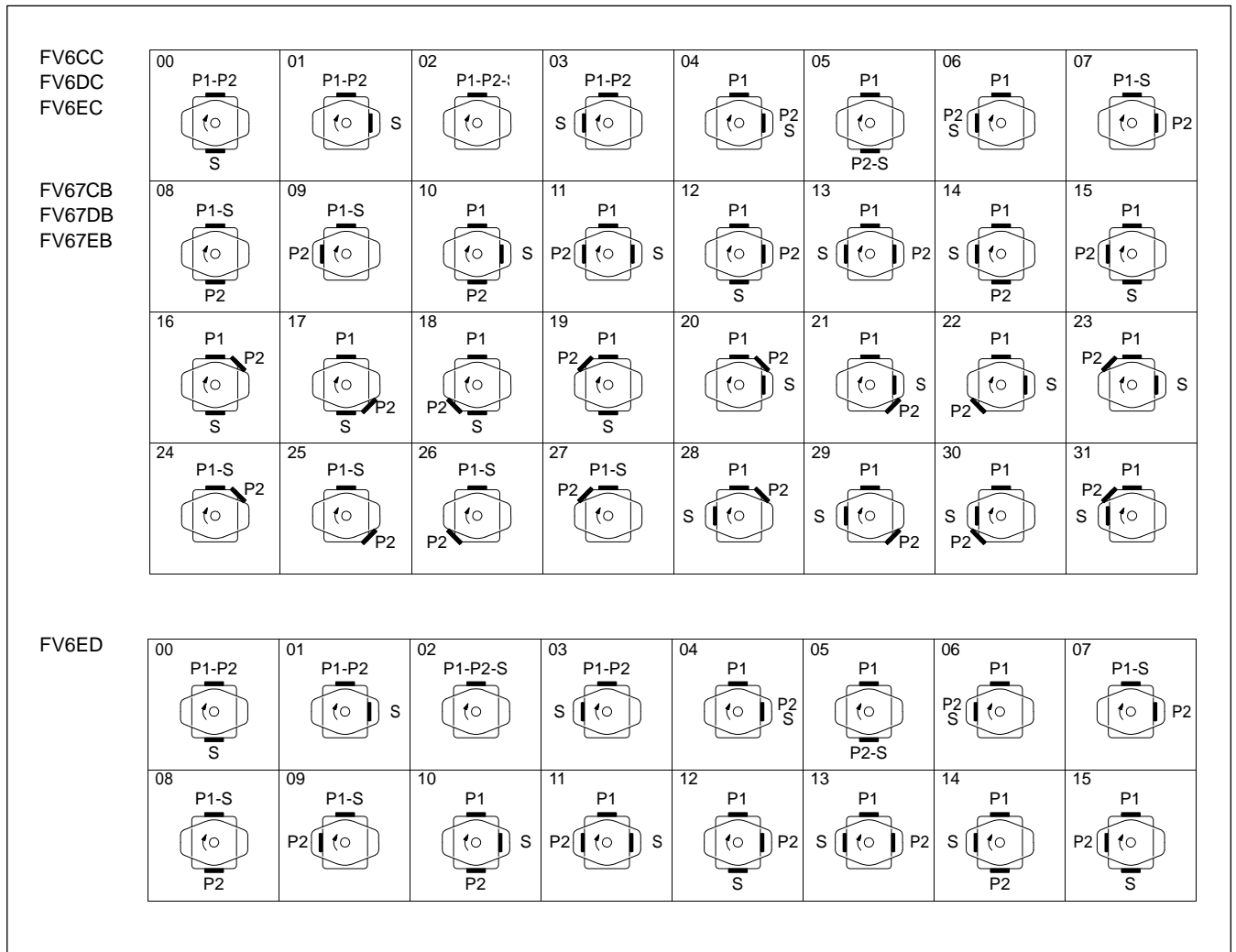



4 - HYDRAULIC FLUID

Data in this catalogue have been obtained with antiwear fluid petroleum base. Minimum allowable inlet pressure 0,8 absolute bar (-0,2 relative bars). Differential pressure between inlet and outlet pressure should be at least 1.5 bar.

Pressures, maximum allowed speeds and recommended temperatures are shown in the table below, according to the types of hydraulic fluid used.

FLUID TYPE	NOTES
HFC (water glycol solutions with proportion of water \leq 40%)	The performance ratings shown in the table 'PERFORMANCES' must be reduced as follows: max continuous pressure: 140 bar (FV6E-085 is 75 bar) max peak pressure: 175 bar (FV6E-085 is 75 bar) max rotation speed: 1800 rpm - Minimum allowable inlet pressure 1 absolute bar - The fluid maximum temperature must be between 10°C and 50°C. - Use NBR seals only. - Minimum viscosity 18 cSt
HFD (phosphate esters)	The performance ratings shown in the table 'PERFORMANCES' must be reduced as follows: max continuous pressure: 175 /160 bar (FV6E-085 is 80 bar) max peak pressure: 210 bar (FV6E-085 is 120 bar) max rotation speed: 1800 rpm - Minimum allowable inlet pressure 1,08 absolute bar - The fluid temperature must be between -18°C and 70°C. - Use VITON seals - Minimum viscosity 18 cSt

4.2 - Fluid viscosity

The operating fluid viscosity must be within the following range:

minimum viscosity	10 cSt	referred to the maximum temperature of 90 °C of the fluid, with antiwear
optimum viscosity	30 cSt	referred to the operating temperature of the fluid in the tank
maximum viscosity	840 cSt	limited to only the pump start-up phase at cold start.

When choosing the fluid type, verify that the true viscosity at the operating temperature is within the above range.

4.3 - Degree of fluid contamination

The degree of fluid contamination must be according to ISO 4406:1999 class 19/17/14 or better. Strainers on inlet port are not recommended. However, if requested, do not exceed 149 micron (100 mesh).

5 - CHARACTERISTIC CURVES OF SINGLE PUMPS

5.1 - FV6C

INTERNAL LEAKAGE (typical)

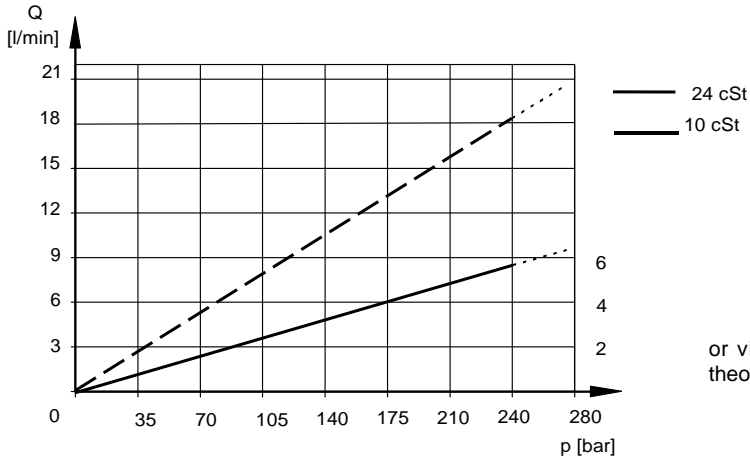

or viscosity if the internal leakage is more than 50% of theoretical flow.

PERMISSIBLE RADIAL LOAD

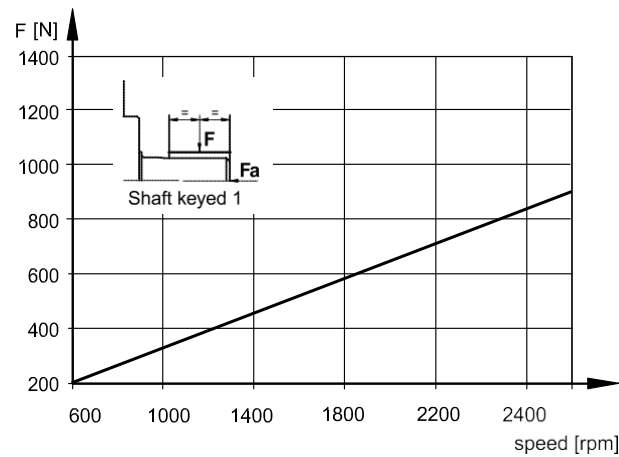

Maximum permitted axial load $F_a = 800$ N

NOISE LEVEL (typical)

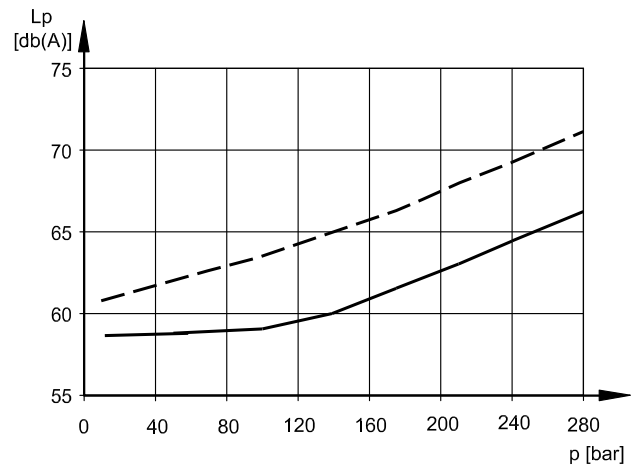

Value obtained with a FV6C-22 pump, according to ISO 4412
1 mt distance

— 1000 rpm
- - 1500 rpm

POWER LOSS HYDROMECHANICAL (typical)

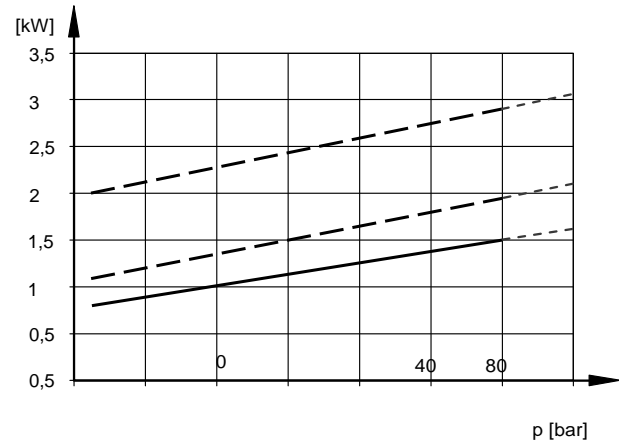

— n = 1000 RPM
- - n = 1500 RPM [24 cSt]
... n = 2800 RPM

ABSORBED POWER at 1500 rpm

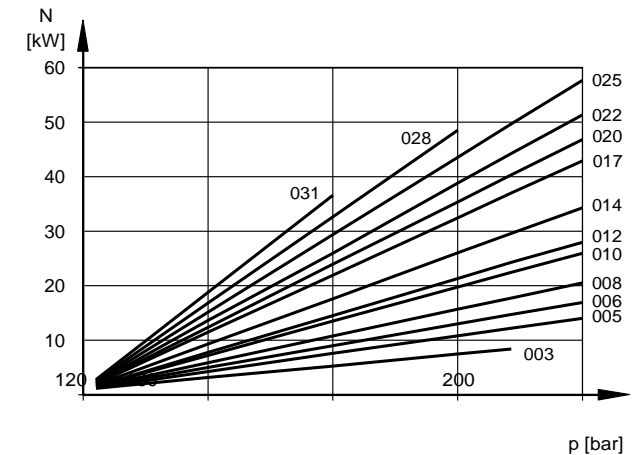

D 280
0 0

170

21
0

280

FV6

SERIES 10

5.2 - FV6D

INTERNAL LEAKAGE (typical)

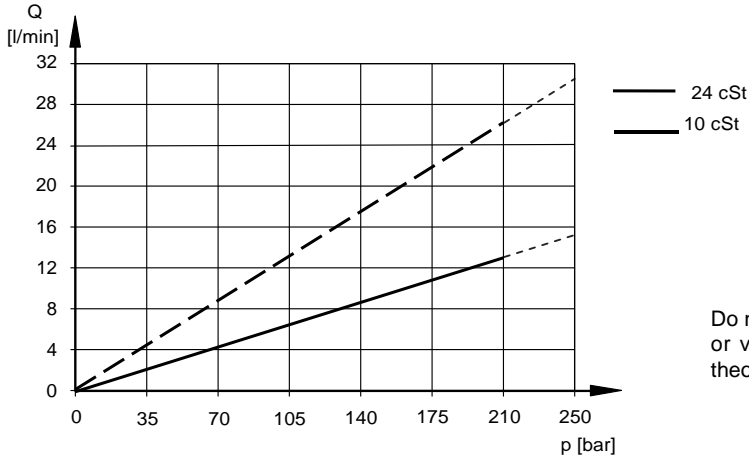

Do not operate the pump more than 5 seconds at any speed or viscosity if the internal leakage is more than 50% of theoretical flow.

PERMISSIBLE RADIAL LOAD

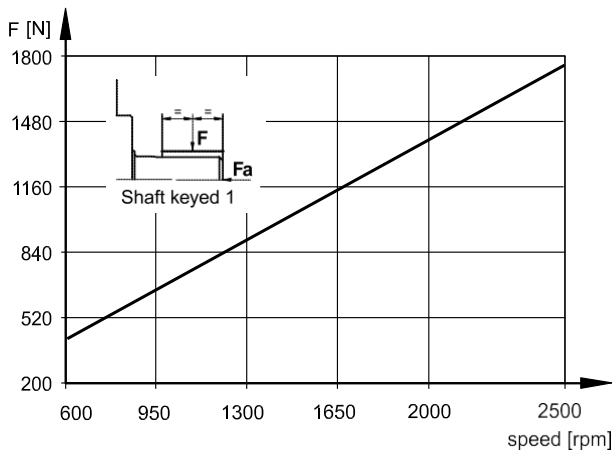

Maximum permitted axial load $F_a = 1200$ N

NOISE LEVEL (typical)

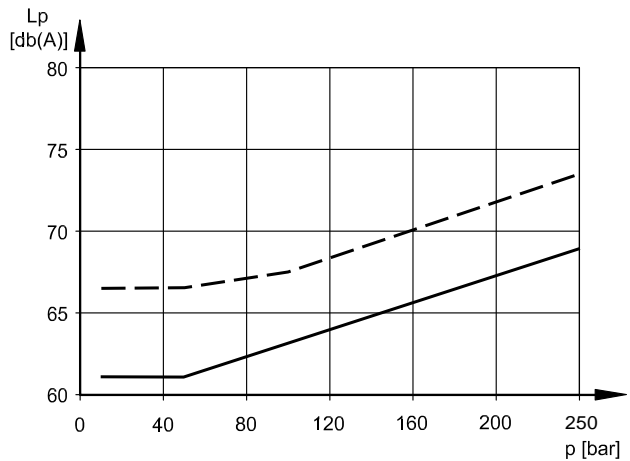

Value obtained with a FV6D-38 pump, according to ISO 4412
1 mt distance

POWER LOSS HYDROMECHANICAL (typical)

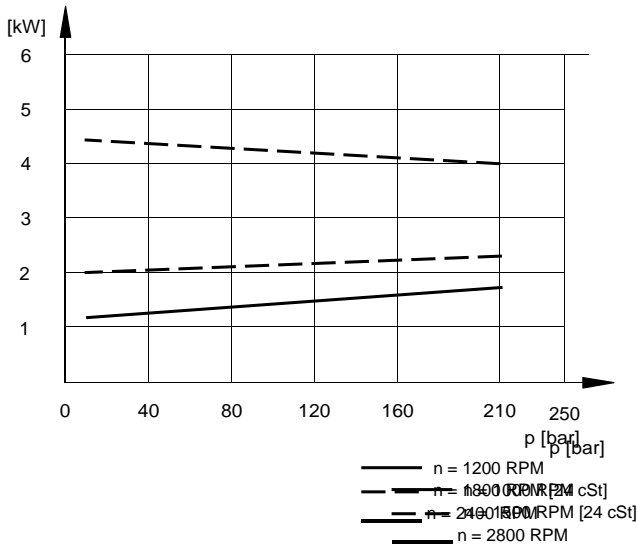

ABSORBED POWER at 1500 rpm

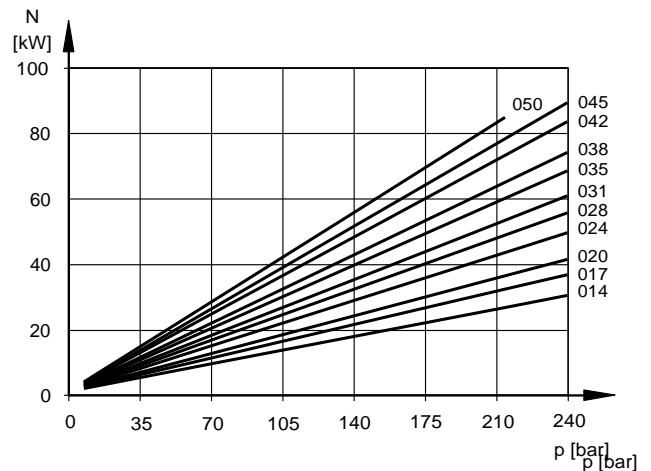

5.3 - FV6E

INTERNAL LEAKAGE (typical)

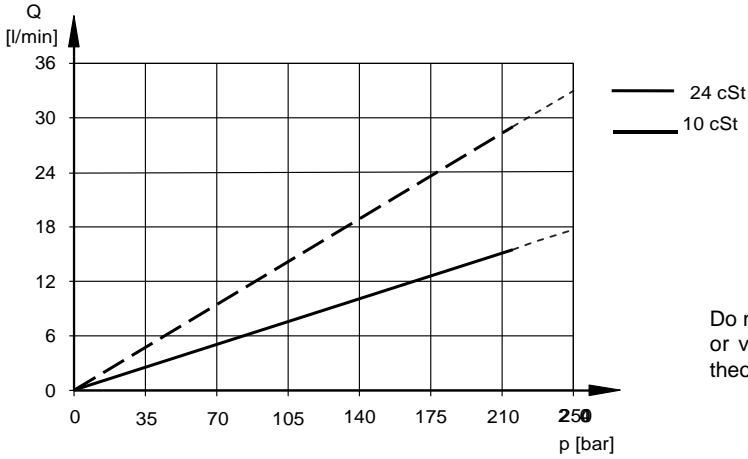

Do not operate the pump more than 5 seconds at any speed or viscosity if the internal leakage is more than 50% of theoretical flow.

PERMISSIBLE RADIAL LOAD

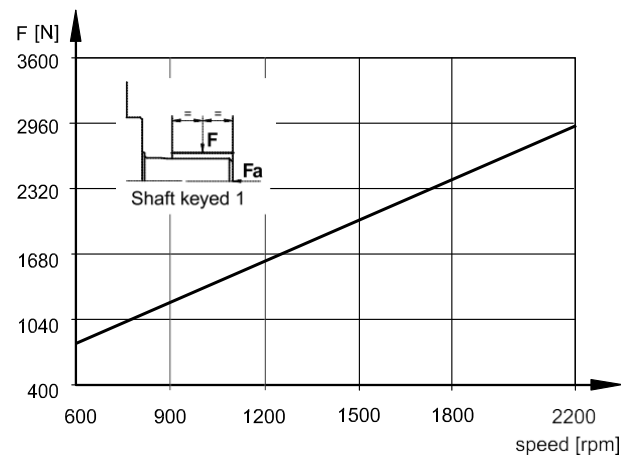

Maximum permitted axial load $F_a = 2000$ N

NOISE LEVEL (typical)

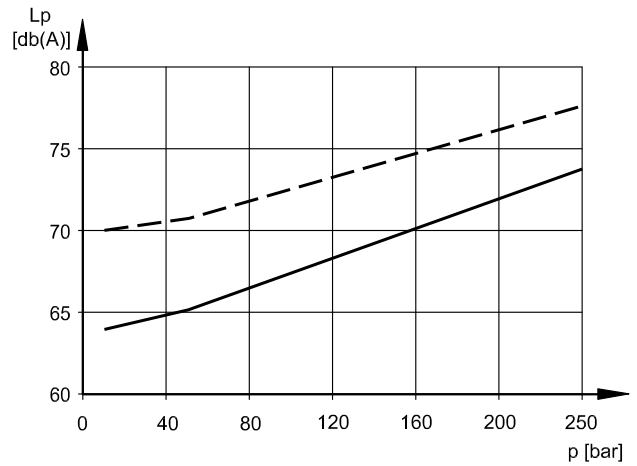

Value obtained with a FV6E-50 pump, according to ISO 4412
1 mt distance

POWER LOSS HYDROMECHANICAL (typical)

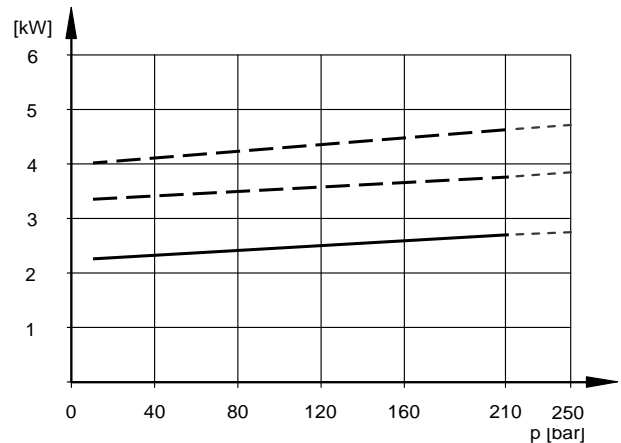

— $n = 1200$ RPM
- - $n = 1800$ RPM [24 cSt]
... $n = 2200$ RPM

ABSORBED POWER at 1500 rpm

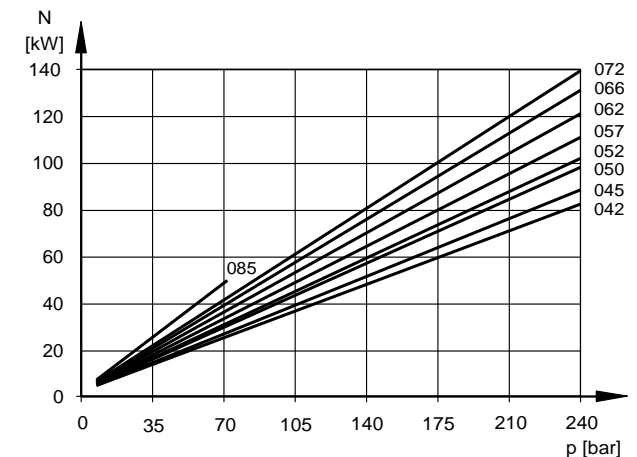

6 - CHARACTERISTIC CURVES OF DOUBLE PUMPS

6.1 - FV6CC

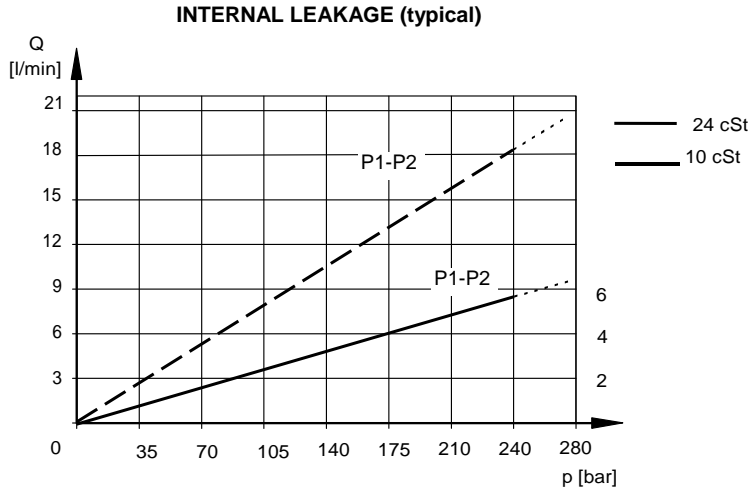

Do not operate pump more than 5 seconds at any speed or viscosity if the internal leakage is more than 50% of theoretical flow
 Total leakage is the sum of each section loss at its operating conditions.

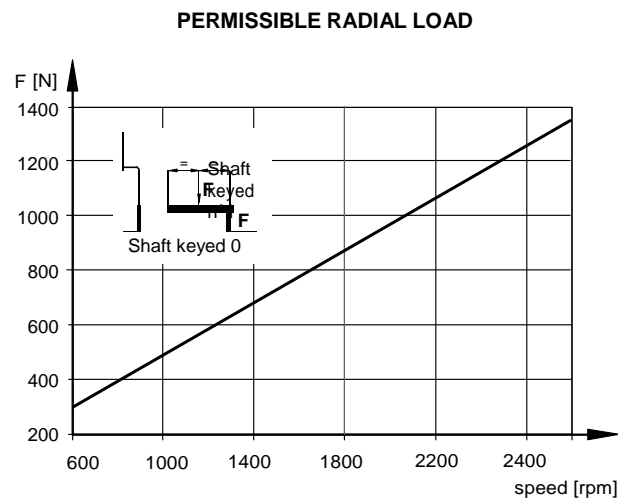

Maximum permitted axial load $F_a = 800$ N

POWER LOSS HYDROMECHANICAL

Refer to diagram of FV6C pump.
 Total hydromechanics power loss is the sum of each section at its operating conditions.

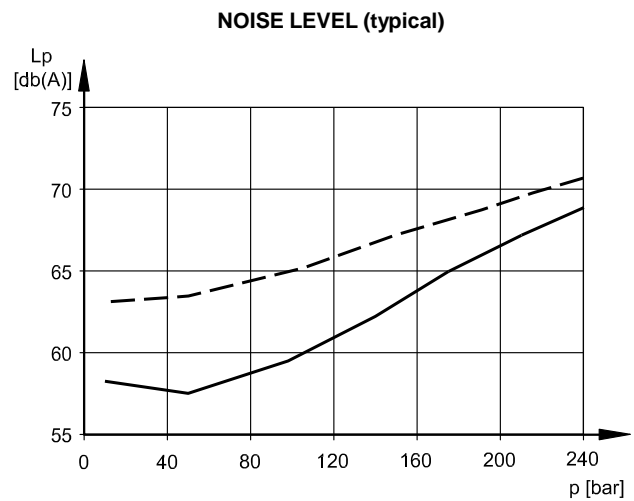

FV6CC-22/22 pump, according to ISO 4412, 1 mt distance.
 Values obtained with $p_e = 0.9$ bar abs and both stages discharging at the same pressure.

6.2 - FV6DC

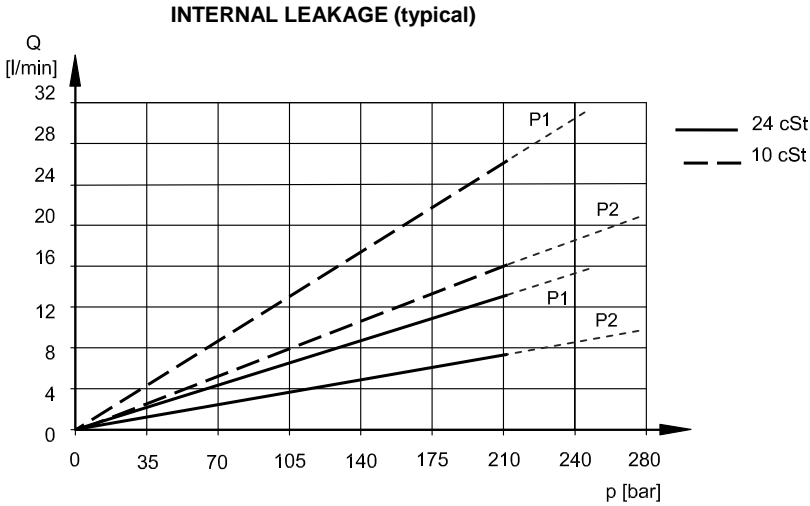

Do not operate pump more than 5 seconds at any speed or viscosity if the internal leakage is more than 50% of theoretical flow
 Total leakage is the sum of each section loss at its operating conditions.

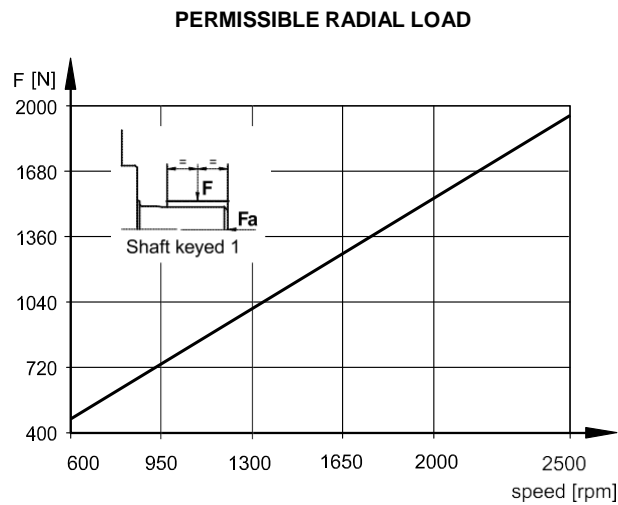

Maximum permitted axial load $F_a = 1200$ N

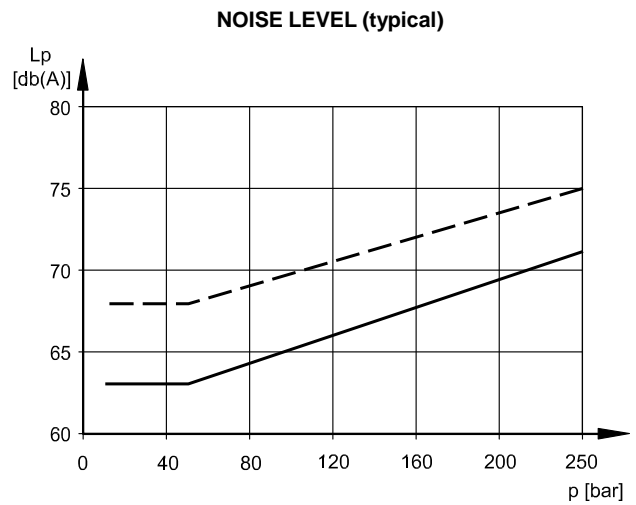

FV6DC-38/22 pump, according to ISO 4412, 1 mt distance

Values obtained with $p_e = 0.9$ bar abs and both stages discharging at the same pressure.

POWER LOSS HYDROMECHANICAL

Refer to diagram of FV6D pump for P1 and to that of FV6C for P2.
 Total hydromechanics power loss is the sum of each section at its operating conditions.

6.3 - FV6EC

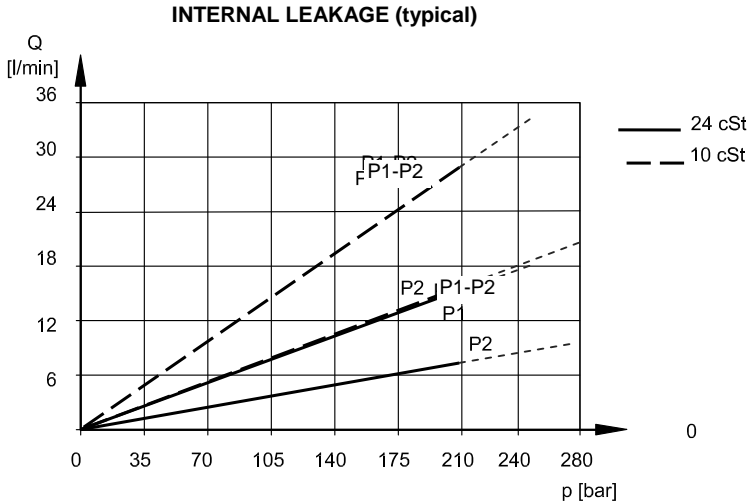

Do not operate pump more than 5 seconds at any speed or viscosity if the internal leakage is more than 50% of theoretical flow

Total leakage is the sum of each section loss at its operating conditions.

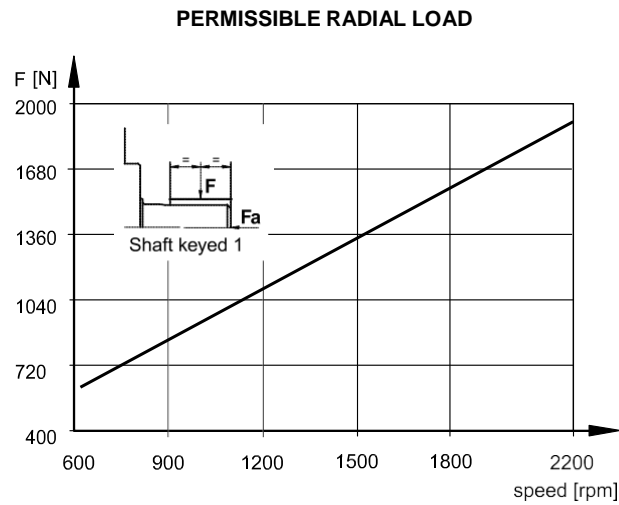

Maximum permitted axial load $F_a = 2000$ N

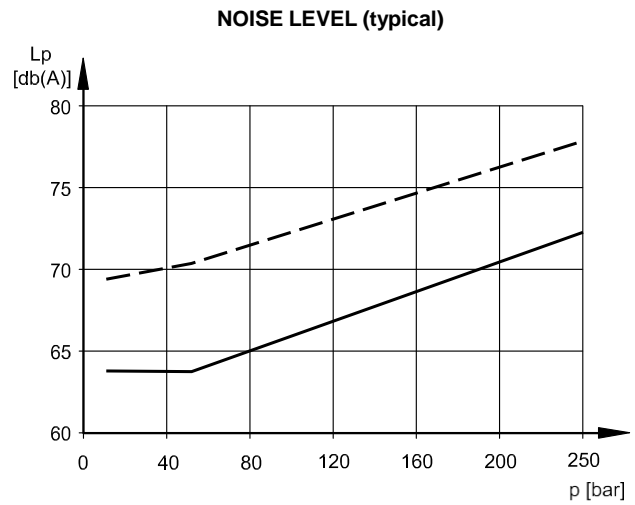

FV6EC-50/22 pump, according to ISO 4412, 1 mt distance.

Values obtained with $p_e = 0.9$ bar abs and both stages discharging at the same pressure.

POWER LOSS HYDROMECHANICAL

Refer to diagram of FV6E pump for P1 and to that of FV6C for P2. Total hydromechanics power loss is the sum of each section at its operating conditions.

6.4 - FV6ED

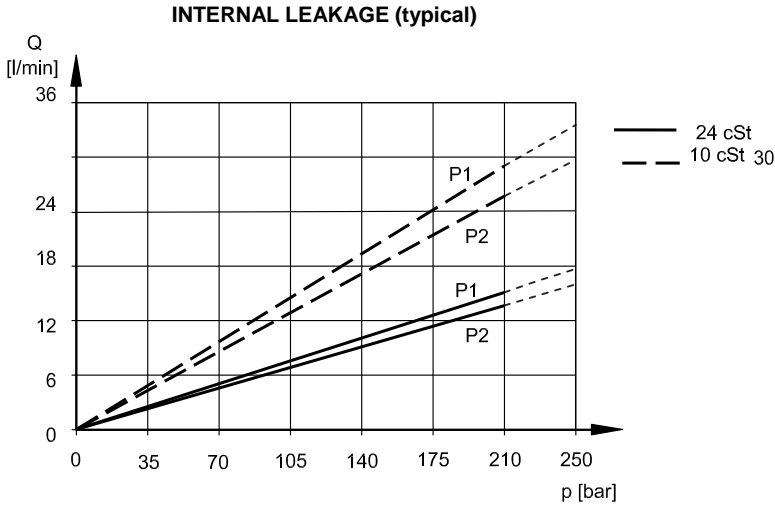

Do not operate pump more than 5 seconds at any speed or viscosity if the internal leakage is more than 50% of theoretical flow
 Total leakage is the sum of each section loss at its operating conditions.

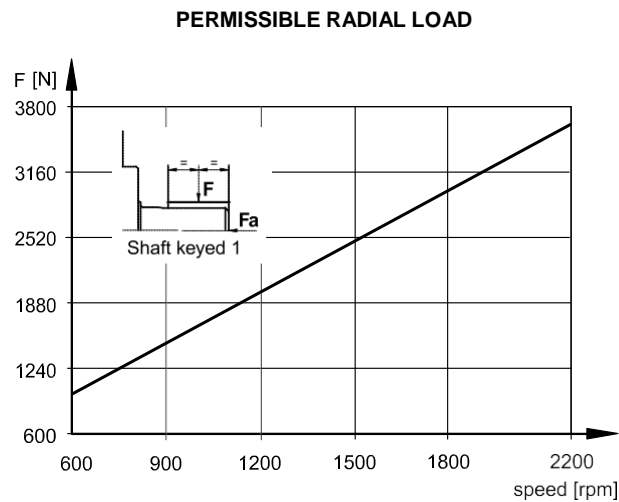

Maximum permitted axial load $F_a = 2000$ N

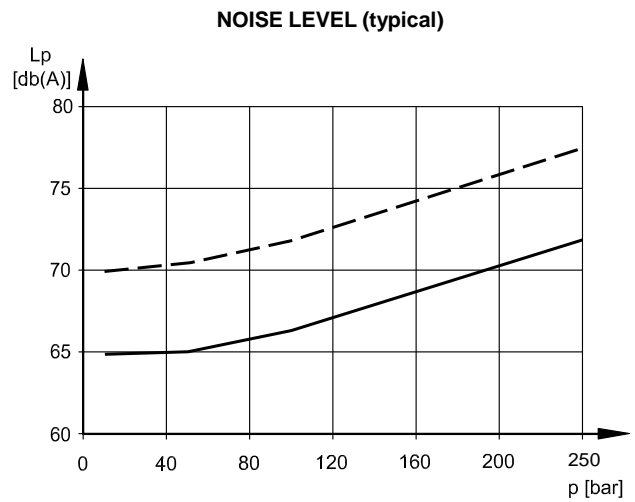

FV6ED-50/38 pump, according to ISO 4412, 1 mt distance
 — 1000 rpm
 - - 1500 rpm

Values obtained with $p_e = 0.9$ bar abs and both stages discharging at the same pressure.

POWER LOSS HYDROMECHANICAL

Refer to diagram of FV6E pump for P1 and to that of FV6D for P2.
 Total hydromechanics power loss is the sum of each section at its operating conditions.



7 - SINGLE PUMPS OVERALL AND MOUNTING DIMENSIONS

7.1 - FV6C

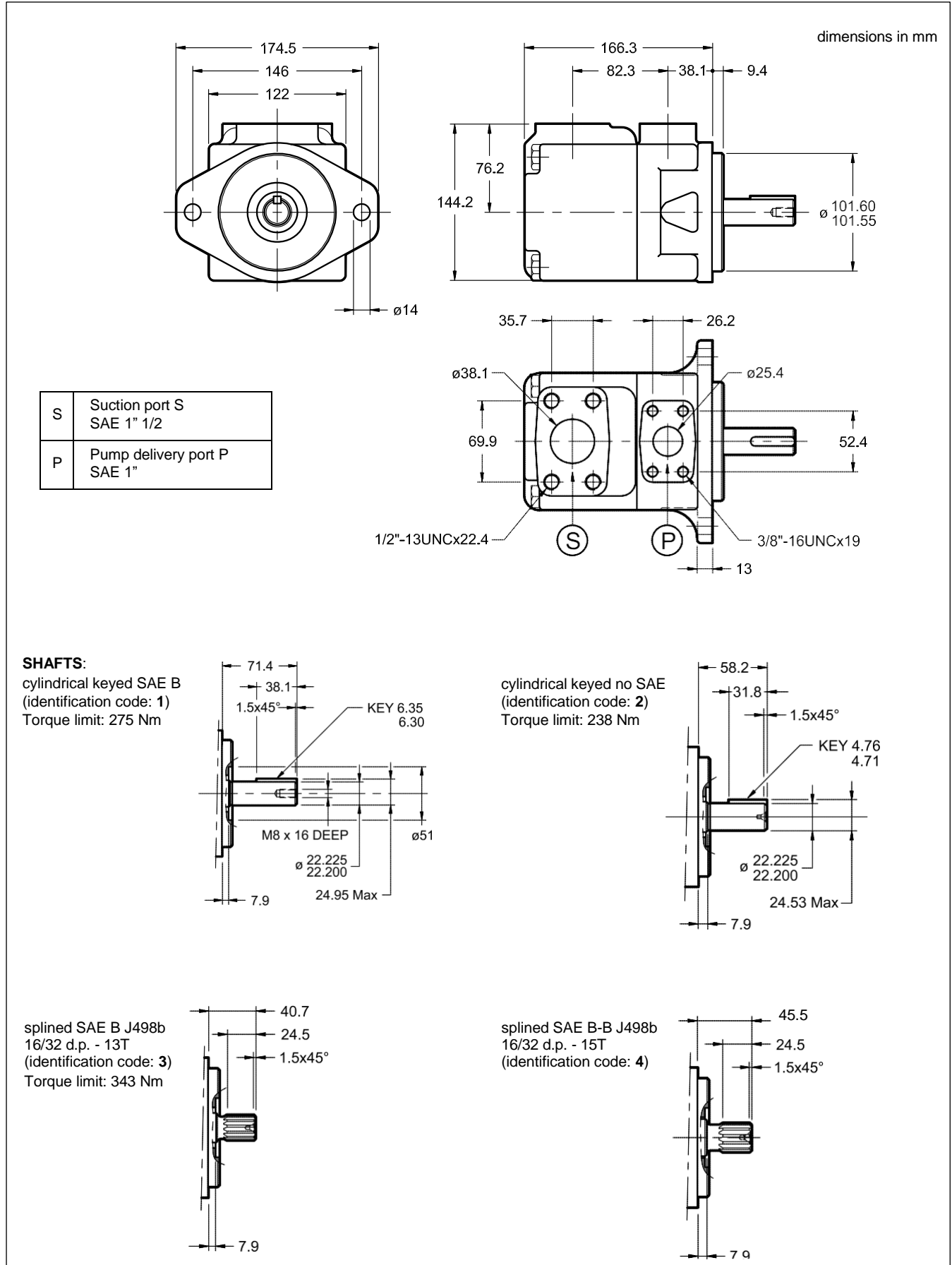

7.2 - FV6D

dimensions in mm

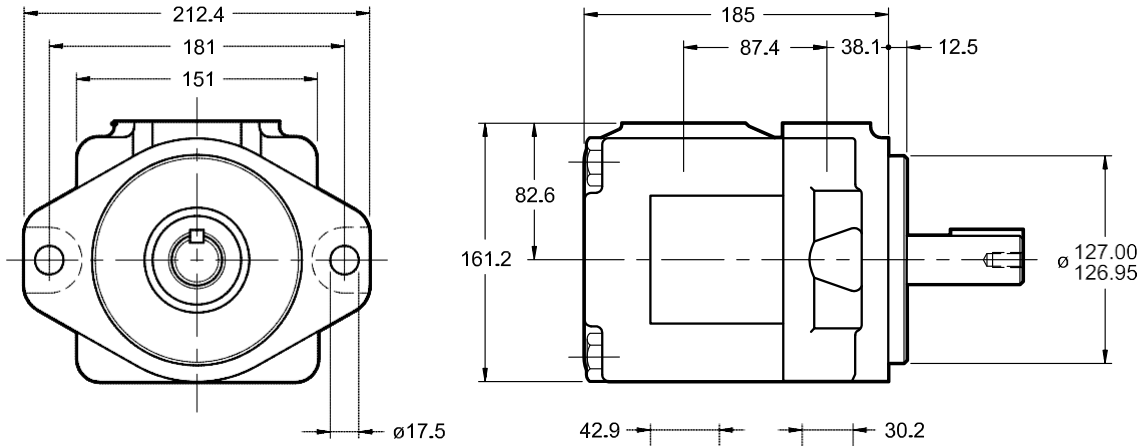

S	Suction port S SAE 2"
P	Pump delivery port P SAE 1" 1/4

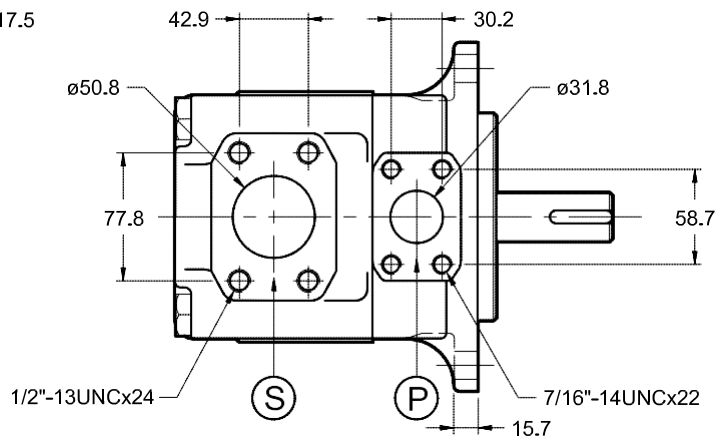

SHAFTS:

cylindrical keyed SAE C
(identification code: 1)

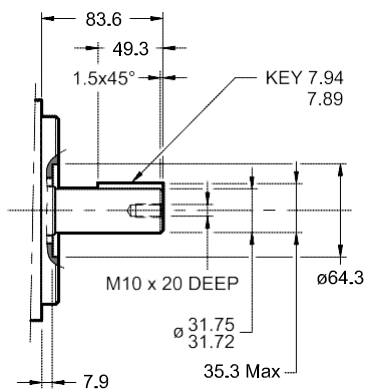

cylindrical keyed no SAE
(identification code: 2)
Torque limit: 577 Nm

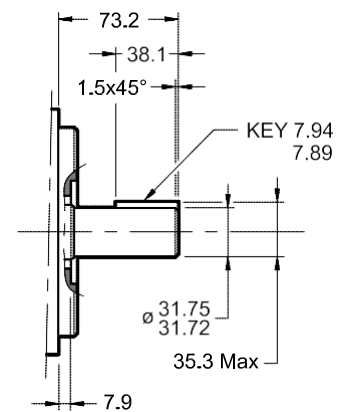

splined SAE C J498b
12/24 d.p. - 14T
(identification code: 3)

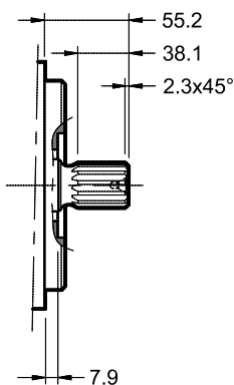

splined no SAE
12/24 d.p. - 14T
(identification code: 4)

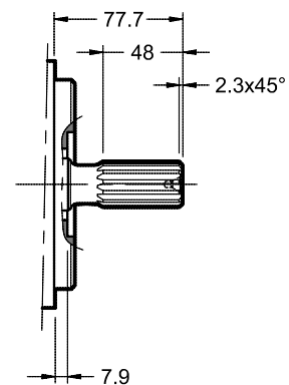

7.3 - FV6E

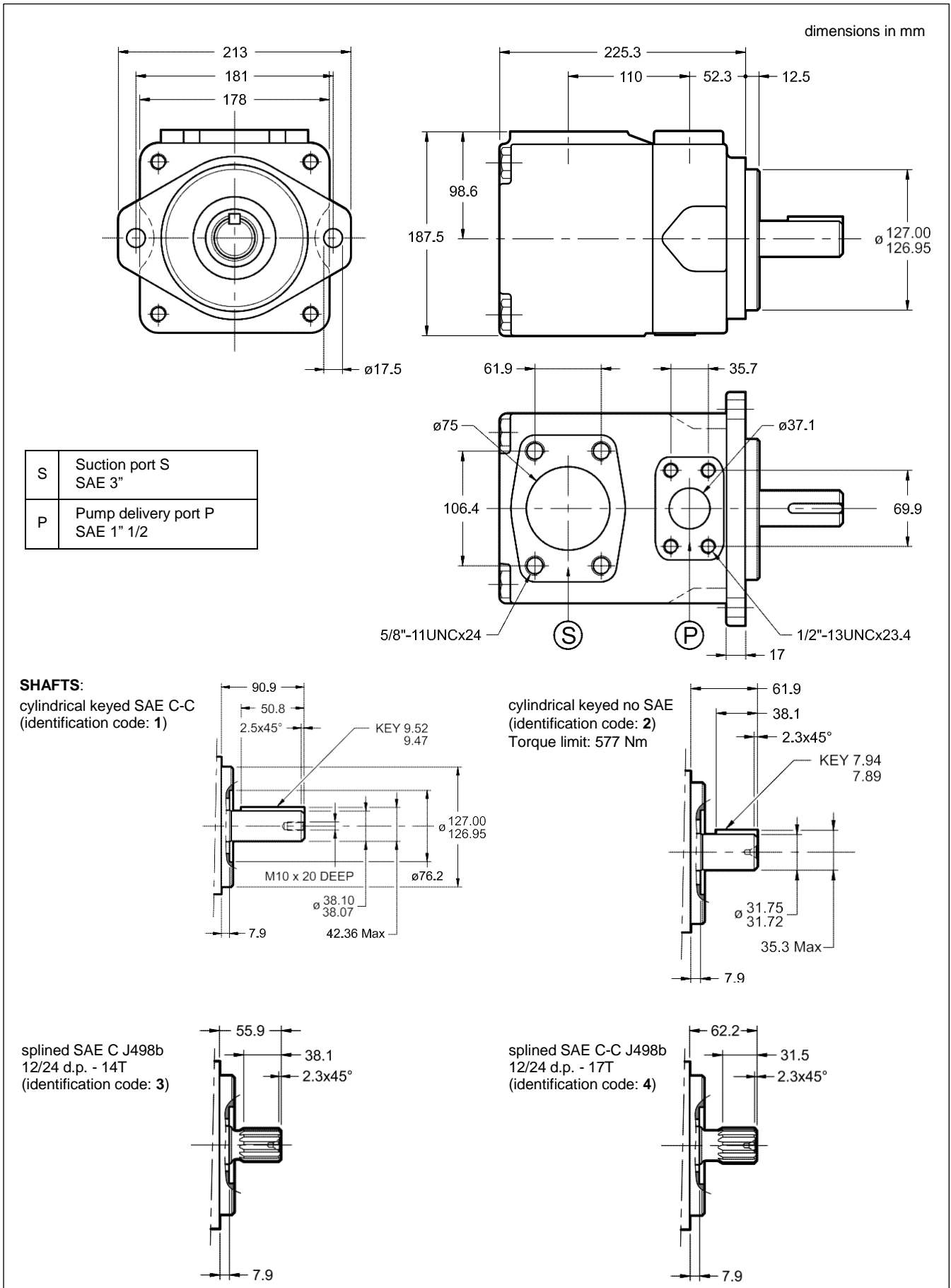

8 - FV6 DOUBLE PUMPS OVERALL AND MOUNTING DIMENSIONS

8.1 - FV6CC

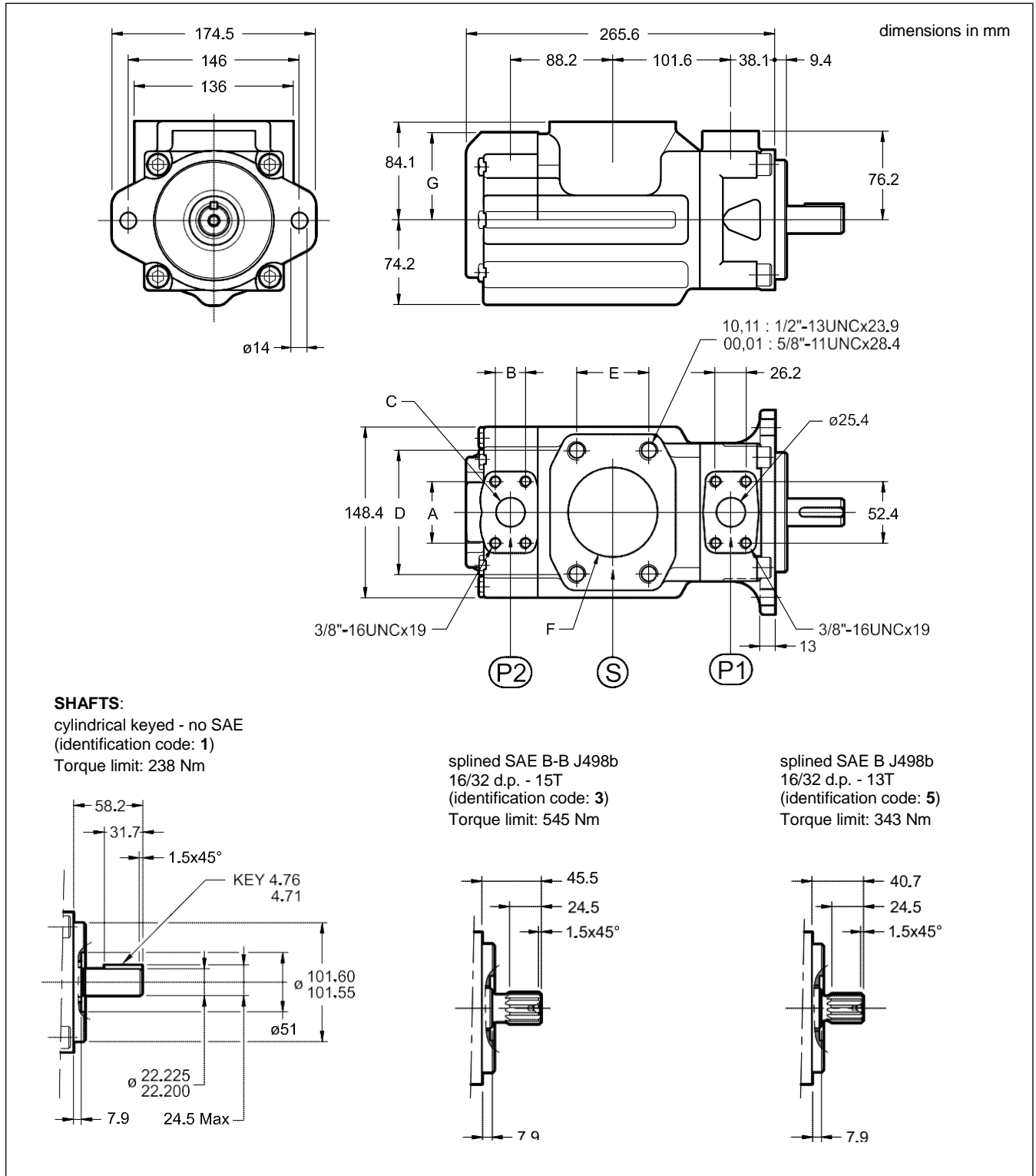

SHAFTS:

cylindrical keyed - no SAE
(identification code: 1)
Torque limit: 238 Nm

splined SAE B-B J498b
16/32 d.p. - 15T
(identification code: 3)
Torque limit: 545 Nm

splined SAE B J498b
16/32 d.p. - 13T
(identification code: 5)
Torque limit: 343 Nm

	dimensions (mm)						
	P2			S			height
	A	B	ØC	D	E	ØF	G
00	52.4	26.2	25.4	106.4	61.9	76.2	74.7
01	47.6	22.2	19.0	106.4	61.9	76.2	76.2
10	52.4	26.2	25.4	88.9	50.8	63.5	74.7
11	47.6	22.2	19.0	88.9	50.8	63.5	76.2

S	Suction port S: 00, 01 : SAE 3" 10, 11 : SAE 2" 1/2
P1	Delivery port P1: SAE 1"
P2	Delivery port P2: 00, 10 : SAE 1" 01, 11 : SAE 3/4"

8.2 - FV6CCW

dimensions in mm

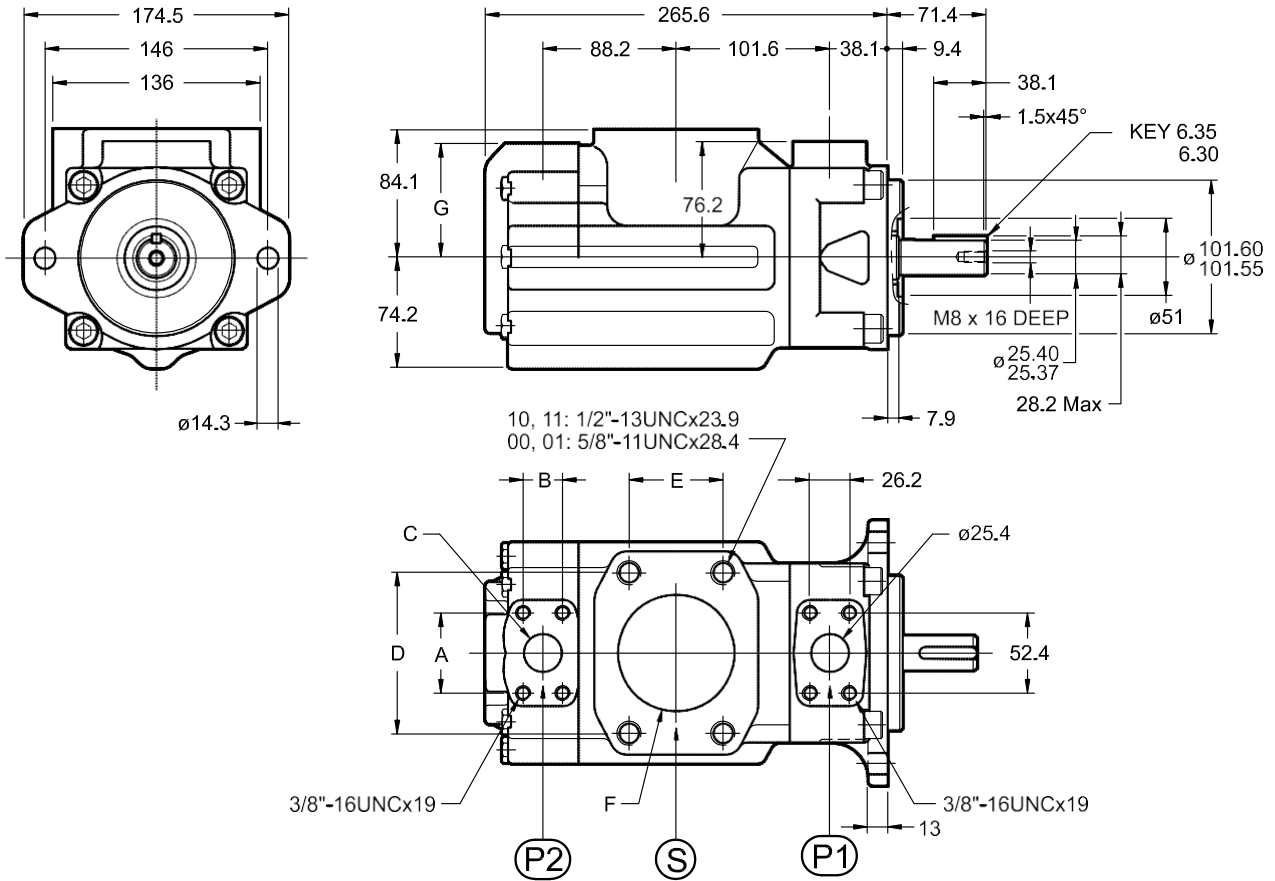

SHAFT:
cylindrical keyed SAE B-B
(identification code: 2)
Torque limit 357 Nm

	dimensions (mm)						
	P2			S			height
	A	B	ϕC	D	E	ϕF	
00	52.4	26.2	25.4	106.4	61.9	76.2	74.7
01	47.6	22.2	19.0	106.4	61.9	76.2	76.2
10	52.4	26.2	25.4	88.9	50.8	63.5	74.7
11	47.6	22.2	19.0	88.9	50.8	63.5	76.2

S	Suction port S: 00, 01 : SAE 3" 10, 11 : SAE 2" 1/2
P1	Delivery port P1: SAE 1"
P2	Delivery port P2: 00, 10 : SAE 1" 01, 11 : SAE 3/4"

8.3 - FV6DC

dimensions in mm

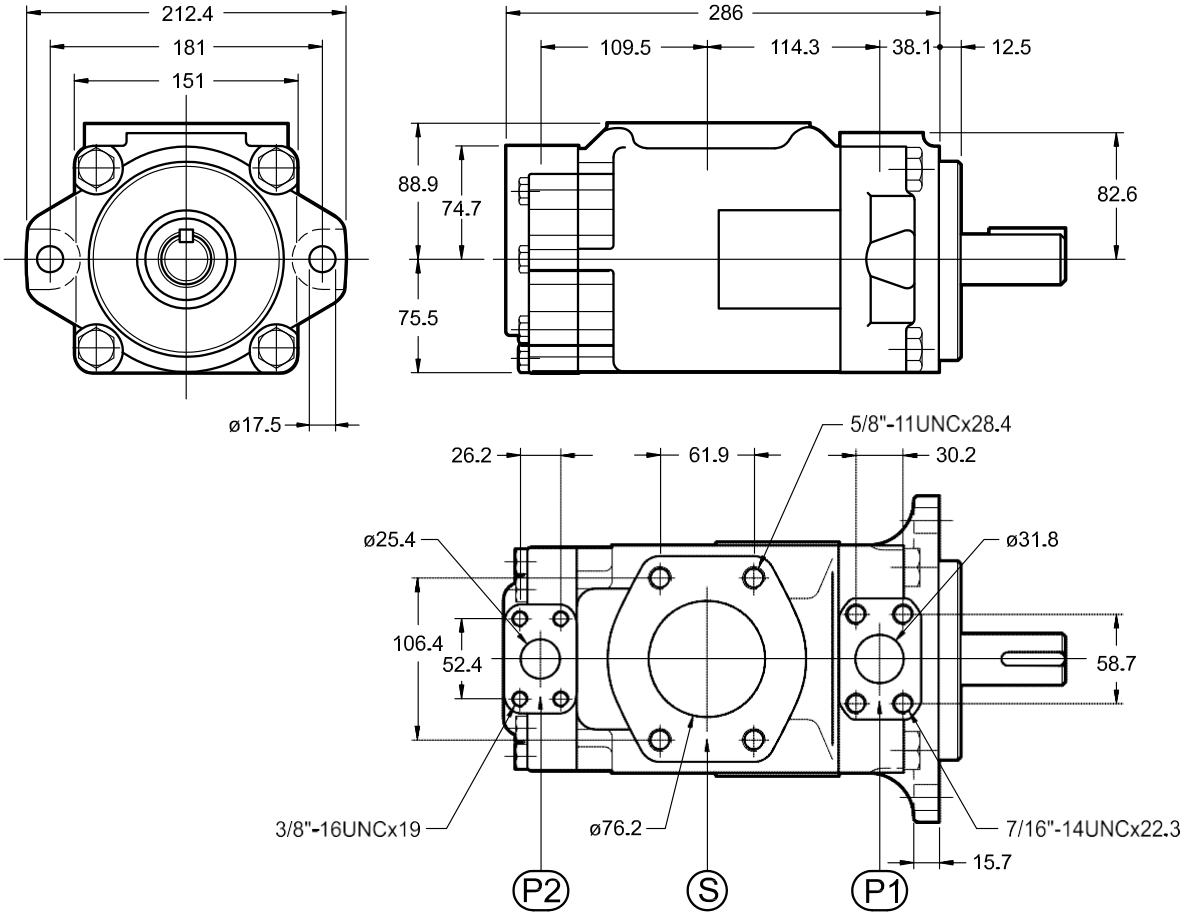

SHAFTS:

cylindrical keyed SAE C
(identification code: 1)
Torque limit: 721 Nm

cylindrical keyed - no SAE
(identification code: 2)
Torque limit: 577 Nm

splined SAE C J498b
12/24 d.p. - 14T
(identification code: 3)

splined - no SAE
12/24 d.p. - 14T
(identification code: 4)

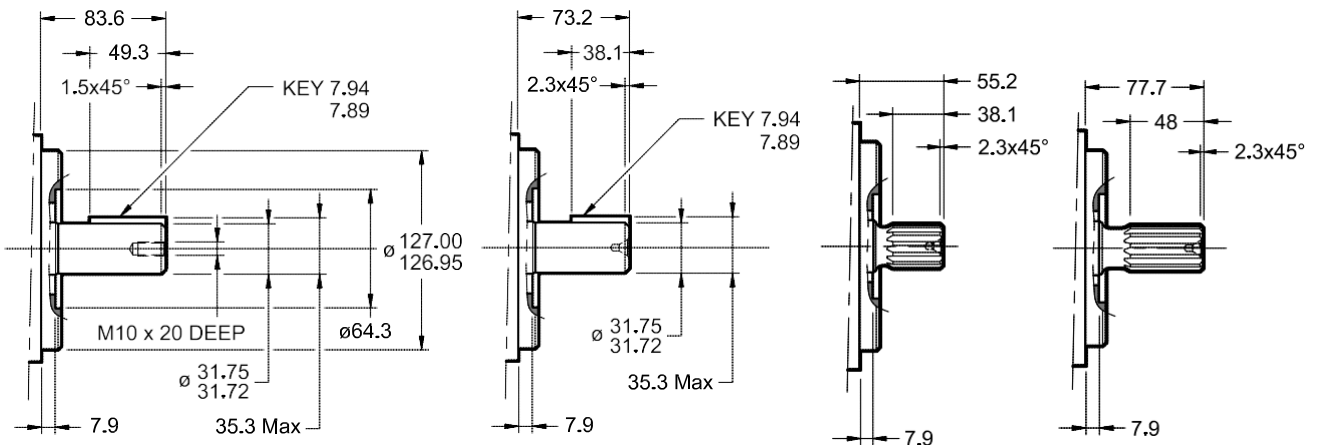

S	Suction port S SAE 3"
P1	Delivery port P1: SAE 1" 1/4
P2	Delivery port P2: SAE 1"

8.5 - FV6EC

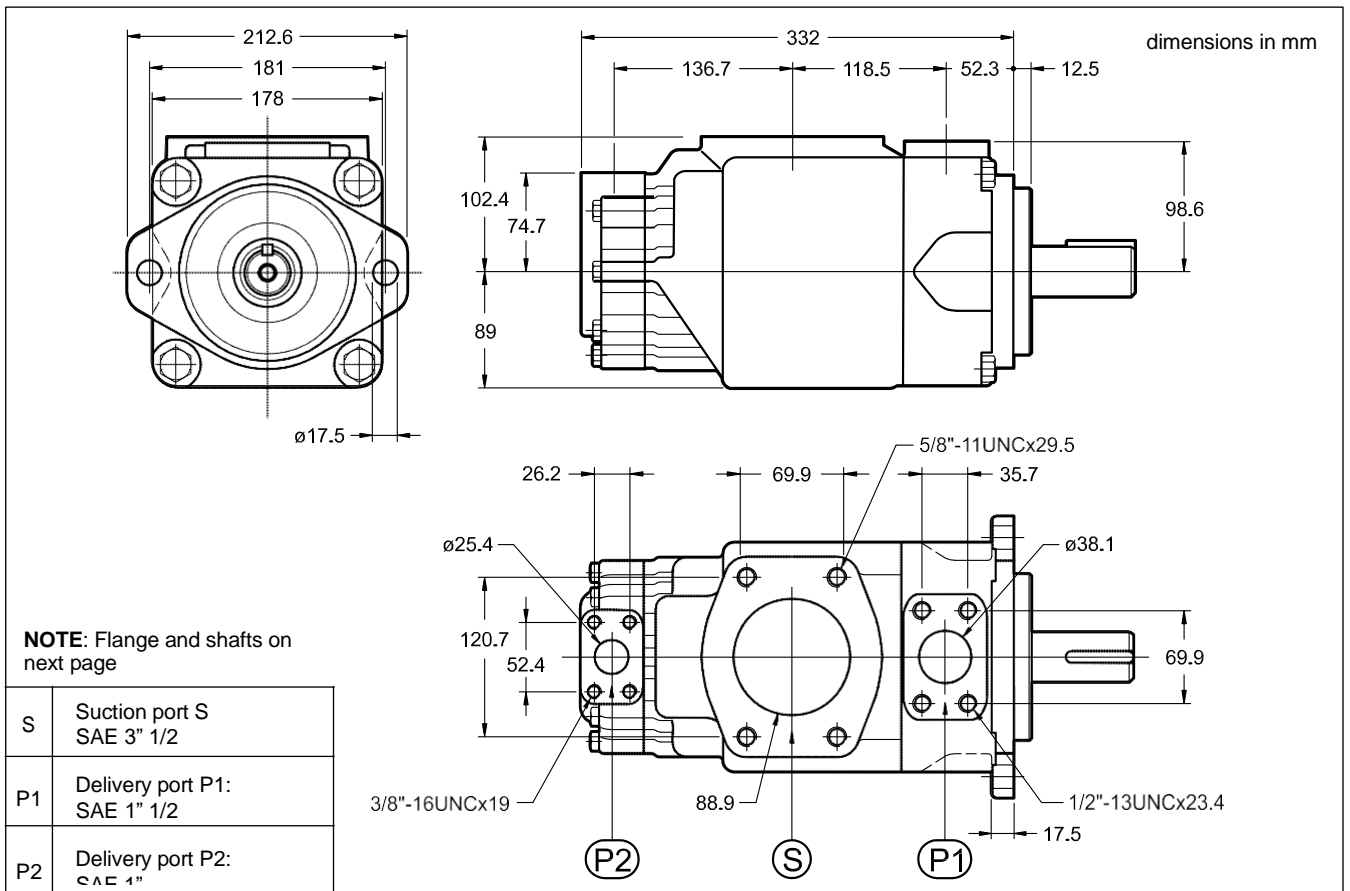

8.6 - FV6ED

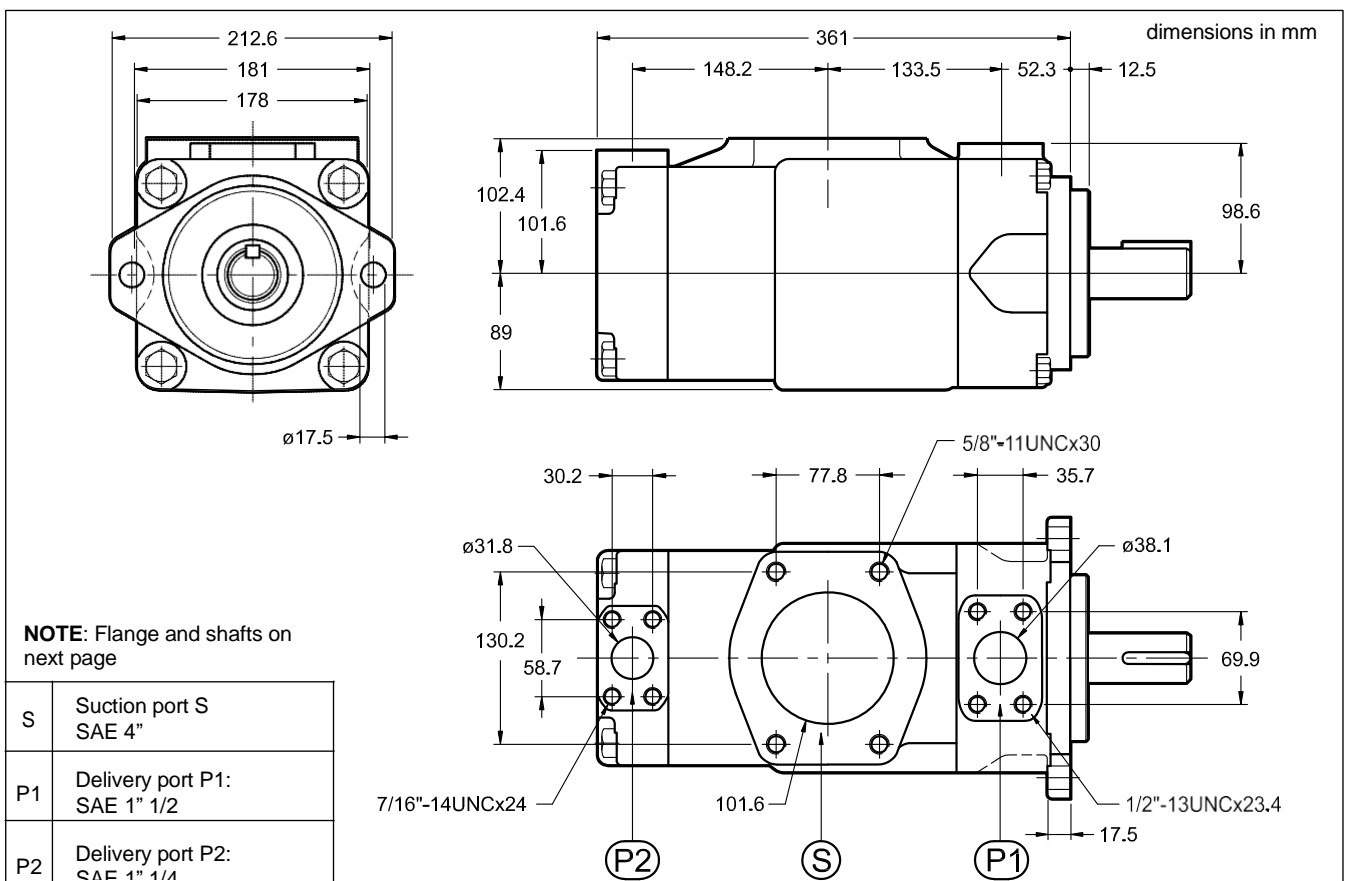

8.7 - Shafts for FV6EC and FV6ED

cylindrical keyed SAE C-C
(identification code: 1)

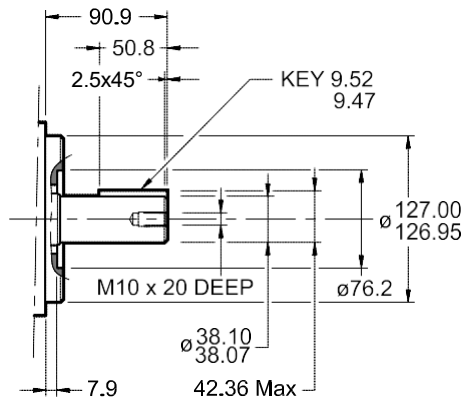

cylindrical keyed - no SAE
(identification code: 2)
Torque limit: 577 Nm

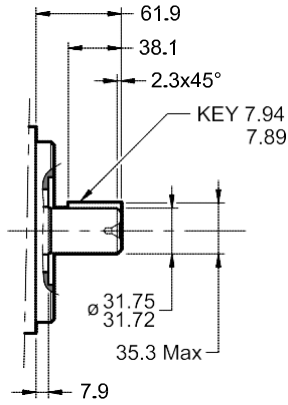

splined SAE C J498b
12/24 d.p. - 14T
(identification code: 3)

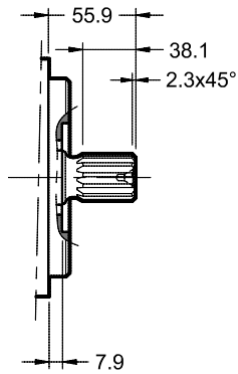

splined SAE C-C J498b
12/24 d.p. - 17T
(identification code: 4)

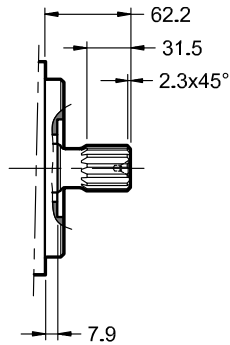

9 - INSTALLATION AND START-UP

- FV6 pumps can be installed in any position. They are normally positioned directly above the oil tank. The installation below the oil level is suggested for circuits with high flow rates and pressures.
 - The suction line must be sized to facilitate the oil flow. Bends and restrictions or an excessive line length could impair the operation of the pump. A bevel on both suction and return lines is recommended to increase the surface and so lower the velocity. We suggest a 45° minimum angle.
 - Check the rotation direction of the motor is according to the rotation direction shown on the pump label before start up.
 - The pump start-up should occur with the pump unloaded, especially at cold temperatures. Set the pressure relief valve of the circuit to its minimum setting value so the pump is unloaded when started. Circuit priming and air bleed off have to be performed before resetting the pressure relief valve.
 - A minimum pump shaft speed of 600 rpm is recommended for priming. To prevent possible damage to the internal parts, the pump should never be started dry or without internal lubrication. The pump should prime quite instantly (few seconds). If not, shut down and check conditions.
- Pump with positive head: allow the fluid to flow to the pump inlet, loosen the discharge port(s) fitting(s) until the fluid comes out and retighten the discharge line(s). Then start the pump which should prime quite instantly. Purge the air off the circuit, preferably using air bleed off valves or pressure test points. Let the pump discharge several minutes unloaded.
- Pump mounted above fluid level: fill the pump through outlet port(s) with suitable and clean fluid and start rotation in jog mode. Purge the air off the circuit, preferably using air bleed off valves or pressure test points. Let the pump discharge several minutes unloaded.
- The motor-pump coupling must be made directly with a flexible coupling. Couplings that generate axial or radial loads on the pump shaft are not allowed.
 - Refer to paragraph 4.3 for the characteristics and installation of the filtering elements.

10 - SAE J518 CONNECTION FLANGES

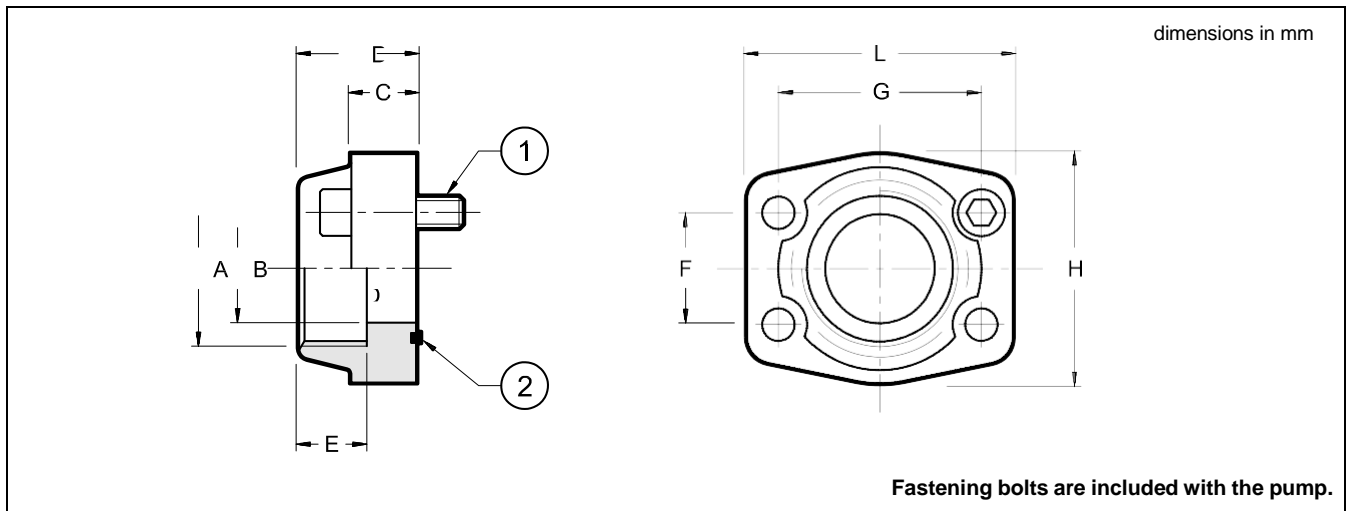

Flange code	Flange description	Pmax [bar]	ØA	ØB	C	D	E	F	G	H	L	1 N. 4 SHC bolts	2
0610719	SAE - 3/4"	345	3/4" BSP	19	18	36	19	22,2	47,6	50	65	3/8" UNC x 1 1/2"	OR 4100
0610713	SAE - 1"	345	1" BSP	25	18	38	22	26,2	52,4	55	70		OR 4131
0610720	SAE - 1 1/4"	276	1 1/4" BSP	32	21	41	22	30,2	58,7	68	79	7/16" UNC x 1 1/2"	OR 4150
0610714	SAE - 1 1/2"	207	1 1/2" BSP	38	25	45	24	35,7	70	78	93	1/2" UNC x 1 3/4"	OR 4187
0610721	SAE - 2"	207	2" BSP	51	25	45	30	43	77,8	90	102		OR 4225
0610722	SAE - 2 1/2"	172	2 1/2" BSP	63	25	50	30	50,8	89	105	116		OR 4175
0610723	SAE - 3"	138	3" BSP	73	27	50	34	62	106,4	116	134	5/8" UNC x 2"	OR 4337
0610724	SAE - 3 1/2"	34	3 1/2" BSP	89	27	48	34	69.9	120.7	136	152		OR 4387
0773528	SAE - 4"	34	4" BSP	99	27	48	34	77.7	130.2	146	162		OR 4437

Архангельск (8182)63-90-72
 Астана (7172)727-132
 Астрахань (8512)99-46-04
 Барнаул (3852)73-04-60
 Белгород (4722)40-23-64
 Брянск (4832)59-03-52
 Владивосток (423)249-28-31
 Волгоград (844)278-03-48
 Вологда (8172)26-41-59
 Воронеж (473)204-51-73
 Екатеринбург (343)384-55-89
 Иваново (4932)77-34-06

Ижевск (3412)26-03-58
 Иркутск (395)279-98-46
 Казань (843)206-01-48
 Калининград (4012)72-03-81
 Калуга (4842)92-23-67
 Кемерово (3842)65-04-62
 Киров (8332)68-02-04
 Краснодар (861)203-40-90
 Красноярск (391)204-63-61
 Курск (4712)77-13-04
 Липецк (4742)52-20-81

Магнитогорск (3519)55-03-13
 Москва (495)268-04-70
 Мурманск (8152)59-64-93
 Набережные Челны (8552)20-53-41
 Нижний Новгород (831)429-08-12
 Новокузнецк (3843)20-46-81
 Новосибирск (383)227-86-73
 Омск (3812)21-46-40
 Орел (4862)44-53-42
 Оренбург (3532)37-68-04
 Пенза (8412)22-31-16

Пермь (342)205-81-47
 Ростов-на-Дону (863)308-18-15
 Рязань (4912)46-61-64
 Самара (846)206-03-16
 Санкт-Петербург (812)309-46-40
 Саратов (845)249-38-78
 Севастополь (8692)22-31-93
 Симферополь (3652)67-13-56
 Смоленск (4812)29-41-54
 Сочи (862)225-72-31
 Ставрополь (8652)20-65-13

Сургут (3462)77-98-35
 Тверь (4822)63-31-35
 Томск (3822)98-41-53
 Тула (4872)74-02-29
 Тюмень (3452)66-21-18
 Ульяновск (8422)24-23-59
 Уфа (347)229-48-12
 Хабаровск (4212)92-98-04
 Челябинск (351)202-03-61
 Череповец (8202)49-02-64
 Ярославль (4852)69-52-93

Киргизия (996)312-96-26-47

Россия (495)268-04-70

Казахстан (772)734-952-31